

RootsScrub RB 800/950

Ride-On Scrubber Drier

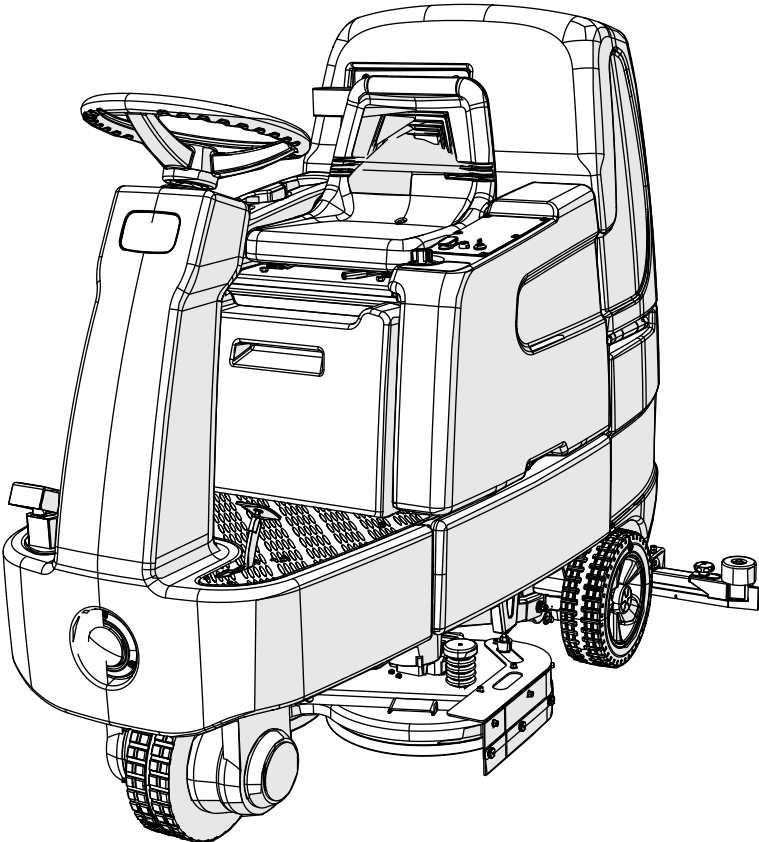

Instruction Manual & Illustrated Parts List

Description	Page No
Introduction	4
Technical Specification	5
General Safety Instructions	6
Initial Setup	8
Operation Brush	11
Operation Squeegee	11
Procedure for Scrubbing	12
Maintenance	13
Battery System	18
Illustrated Parts List	21

Please be advised explicitly that we cannot accept any legal claims out of the contents of this manual. If repair work has to be performed, make sure that only genuine spare parts are used since genuine spare parts only may guarantee continuous and dependable operation of your machine.

Roots Multiclean Ltd.
RKG Industrial Estate,
Coimbatore - 641 006, India.

Preface

Dear Customer,
We are pleased with your having chosen the **RootsScrub RB 800/950** machine for your floor cleaning requirements. Backed by our industry expertise that spans across decades, we assure you that the machine comes with our Roots promise of quality, efficiency and performance.

We advise you to carefully read through the instructions prior to the operation of the machine. This manual contains detailed instructions for the proper operation of the machine, along with important information regarding its handling, care, maintenance and service needs.

We are sure that you will find the machine and its performance to your utmost satisfaction. Once again, we thank you for choosing Roots Multiclean Ltd. (RMCL) as a trusted partner for your cleaning requirements and solutions.

Usage and Handling

Use of the product beyond the specified scope of functioning is deemed improper and the manufacturer cannot be held liable for any damages which may arise due to this.

This machine may be used only by persons who are trained or are familiar with the machine and are aware of the possible hazards involved. The appropriate Accident Prevention Regulations as well as applicable general regulations pertaining to Safety and Health at the work place must be adhered to by the user.

Modifications made to machine without the manufacturer's consent will relieve the manufacturer of responsibility and any possible liability for consequential damage.

Notes on Domestic Warranty

Please refer to the **Limited Warranty card supplied along with the machine** for additional information. This Warranty Policy is applicable only for the product sold within India. If the product requires repair or maintenance work to be performed, please ensure that you get the machine serviced from an authorised service center or dealer of RMCL to ensure that the warranty is not void.

Acceptance of the Machine

On arrival of the machine at the shipping address, please check for any damage that may have occurred as a result of transit. In the event of any such damage, the purchaser is bound by responsibility to send a claim letter to the concerned RMCL branch/dealer with a copy of the invoice. The letter should be sent within 24 hours of receipt of the machine.

The Manual

All information contained is without obligation. RMCL particularly reserves the right to modify any equipment, technical specifications, colours, shapes, materials and the like so as to adapt them to local conditions all without previous announcement and without giving reasons. RMCL may stop manufacturing certain models without prior notice.

The Owner's Manual corresponds to the latest information available for this machine at the time it was printed. Minor deviations resulting from enhancements of the design cannot be entirely represented.

The Owner's Manual is an integral part of the machine and must not be misplaced.

Roots reserves the right to change the product or contents of this manual without prior information.

For Battery, Motors, Engines and other OEM components related kindly refer to their manufacturers manual supplied along with the machine for instructions regarding usage, maintenance and service.

Please note down the serial number of your machine below:

Serial number:

Date of commissioning:

Description	Units	RB 800	RB 950
Scrubbing width	mm	800	950
Effective suction width	mm	1100	1200
Theoretical area coverage	m ² /h	4800	6175
Working speed, up to	km/h	6	5.5
Travel speed	km/h	6	7
Battery rating	V/Ah	24/240, 320	24/320
Airflow rate	L/sec	33	33
Vacuum pressure	mm of H ₂ O	1650	1650
Power supply	V	24	24
Total power	W	2400	2400
Brush motor power	W	2 X 550	2 X 550
Vacuum motor power	W	550	550
Drive motor power	W	750	750
No. of brushes	No.	2	2
Diameter of brush	mm	405	485
Brush speed	rpm	195	195
Brush load	Kg	43	50
Fresh water tank	L	120	120
Dirty water tank	L	120	120
Dimensions (L x W x H)	mm	1750 x 1100 x 1410	1750 x 1200 x 1410
Total weight empty/with battery	kg	272/490 (240 Ah) 272/540 (320 Ah)	272/540
Total weight ready to operate	kg	600 (240 Ah) 660 (320 Ah)	660
Turning radius	m	1.8	1.8

RootsScrub RB 800

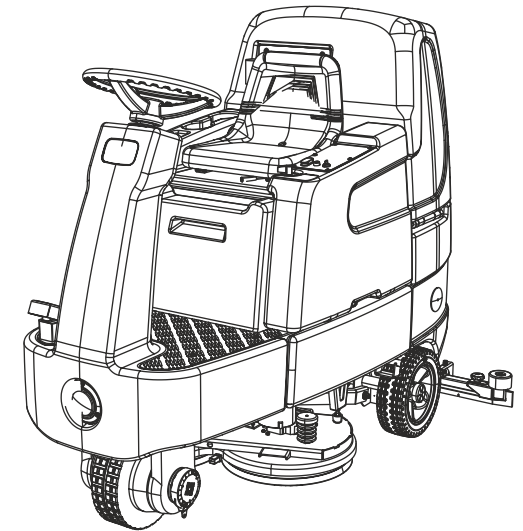



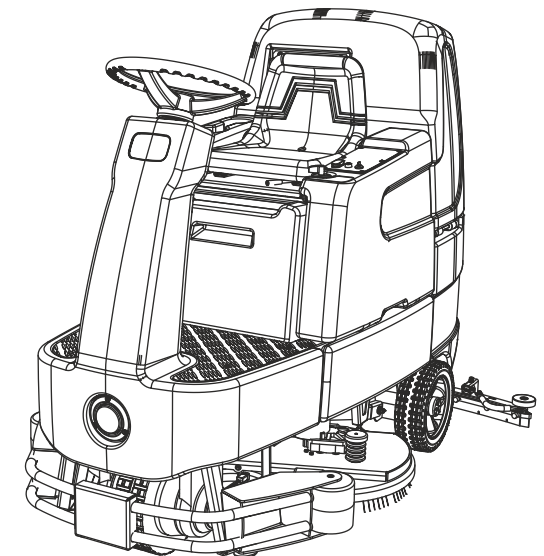

RootsScrub RB 950



Safety & Warning Symbols

All paragraphs in this manual that refer to personal safety, safety of the machine and environmental protection are attributed respective warning symbols as indicated.

 <p>Read manual</p>
<p>Prior to first operation, read the manual carefully and comply with the instructions contained herein without fail.</p>
 <p>Caution (the machine)</p>
<p>Important information on handling the machine in order to maintain operability.</p>
 <p>Ecological hazard (the environment)</p>
<p>Due to use of substances representing an inherent danger to health of environment.</p>
 <p>Safety Provisions (persons & goods)</p>
<p>Safety provisions in dangerous situation caused by misuse inaccurate adherence of instruction or prescribed work routine.</p>

General Guidelines

- In addition to the information contained in this manual, generally applicable legal provisions for Safety and Prevention of accidents must be adhered to.
- Please go through the manual and the instructions contained herein carefully, even if you possess prior experience in operating similar ground cleaning equipment.
- Schedule some time for the careful and thorough perusal of the manual contents.
- The responsibility of all persons in the working area fall upon the operator of the machine.
- No persons, children included, should be allowed within the zone of danger.
- The warning and instruction plates attached to the machine carry important advice on safe operation of the machine.
- Lost or illegible stickers must be replaced at the earliest.
- Prior to operation of the machine, the operator must ensure that the machine and its working implements are in proper and safe operating condition.
- Machines with identified and known defects must not be used.
- It is important that operators and all persons likely to use the machine familiarize themselves with all accessories and controls, as well as their functions, before commencing operation.
- Adherence to the above general instructions will help avoid the operator from having to read the manual while operating the machine.

Safety During Machine Operation

- The machine is applicable for **WET** scrubbing only.
- Ground cleaning machines may be run by qualified personnel only.
- The machine may be used for cleaning such surfaces approved by the owner or this authorized representatives.

- The machine is only suitable for use on the types of surfaces specified in the owner’s manual.
- Protect the machine from frost or extremely low temperatures.
- Never scrub or vacuum explosive liquids, combustible / explosive dusts as well as acids and solvents! This includes diesel, petrol, kerosene, paints, paint thinners, heating oil, etc which can generate explosive fumes on contact with the suction air. Acetone, undiluted acids and aggressive solvents must not vacuumed as it may cause damage to the machine components and brooms.
- Do not scrub/vacuum burning or glowing debris.
- Do not scrub/vacuum in flooded and slushy areas.
- This machine must not be operated by persons (including children) with limited physical ability, sensoric/mental capabilities or lack of experience, unless such persons are supervised by the person in charge.
- Children should be prevented from playing with the machine.
- The operator must use the machine properly. The operator must consider the local conditions and must pay attention to third parties especially children when operating the machine.
- Never leave the machine unattended when the motor is running.
- The operator must leave the machine only after the motor has come to a complete standstill, parking brake applied and the key has been removed.
- Prior to starting work, the operator has to check the machine’s safety devices are working properly.
- The operator must wear tight fitting clothes only. The operator should wear safety shoes only when operating or while carrying out maintenance work.
- Loose fitting clothes or shoes must not be worn by the operator or any maintenance personnel who are intended to work on/with the machine.

- Check the immediate surrounding prior to starting. Ensure sufficient visibility!
- The operator must always use safety gloves, safety helmet, shoes while operating/maintaining the machine.
- On inclined/tilted surfaces, the tilt angle and the driving direction should not exceed the values given in this manual.
- Do not place any tools or metallic objects on top the battery. Risk of short circuit and deflagration!
- Smoking or naked flames are strictly prohibited.
- Always allow the machine sufficient time to cool before carrying out any repair or maintenance work.
- Ensure that there is adequate ventilation for diverting the exhaust gases/dust when operating the machine in a closed area.
- Do not place hand or any object while the brushes are running.
- Suitable tools must be used for cleaning and maintenance work.
- Do not carry out any welding, drilling, sawing or grinding work on the frame sections. Damaged parts may only be changed at an authorized service center.
- It is not permitted to use aggressive and corrosive cleaning agents.
- Used batteries with the recycling symbol must not be disposed of in household waste.
- Maintenance work may be carried out by authorised dealer only.
- Always use appropriate tool and equipments while working on the machine.
- Disconnect the battery when working on electrical system.
- Battery may only be handled and changed by properly skilled maintenance personnel.
- Pay attention that the insulation of the charger cable is not damaged and cannot be damaged during the charging process.

- The cable must not chafe against anything. In the case of defective insulation, do not use the on-board charger.
- When charging the batteries, there must be sufficient ventilation in the charging area. Otherwise, there is a risk of explosion!
- Batteries must not be connected or disconnected when conducting electricity.
- Do not use harsh chemicals to clean the machine.



This machine is not suitable for evacuation of dusts, which are explosive or dangerous to health.

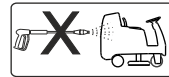

Do not clean the machine by means of vapour jet or high pressure cleaning equipment.

- Before operating the machine kindly use these safety devices:

- Shoes
- Helmet
- Gloves



- ***Do not smoke near machine.***
- ***Do not expose machine to open flames or burning debris.***



The machine may be used only on indoor hard floorings and for operation on level grounds with a maximum inclination of up to 10°.

- The machine is splash-water proof (IPX3).
- This machine is not intended for use on public roads and places. Only qualified personnel must perform maintenance and repair work.
- Turn the machine off and disconnect the mains plug before cleaning and maintaining the machine, when replacing parts or when changing over to another function.

After unpacking

Verify the machine and accessories with the invoice copy. Check the machine for any transit damage, if found contact the branch/dealer immediately.

 Owner's personnel are not allowed to unpack the machine.

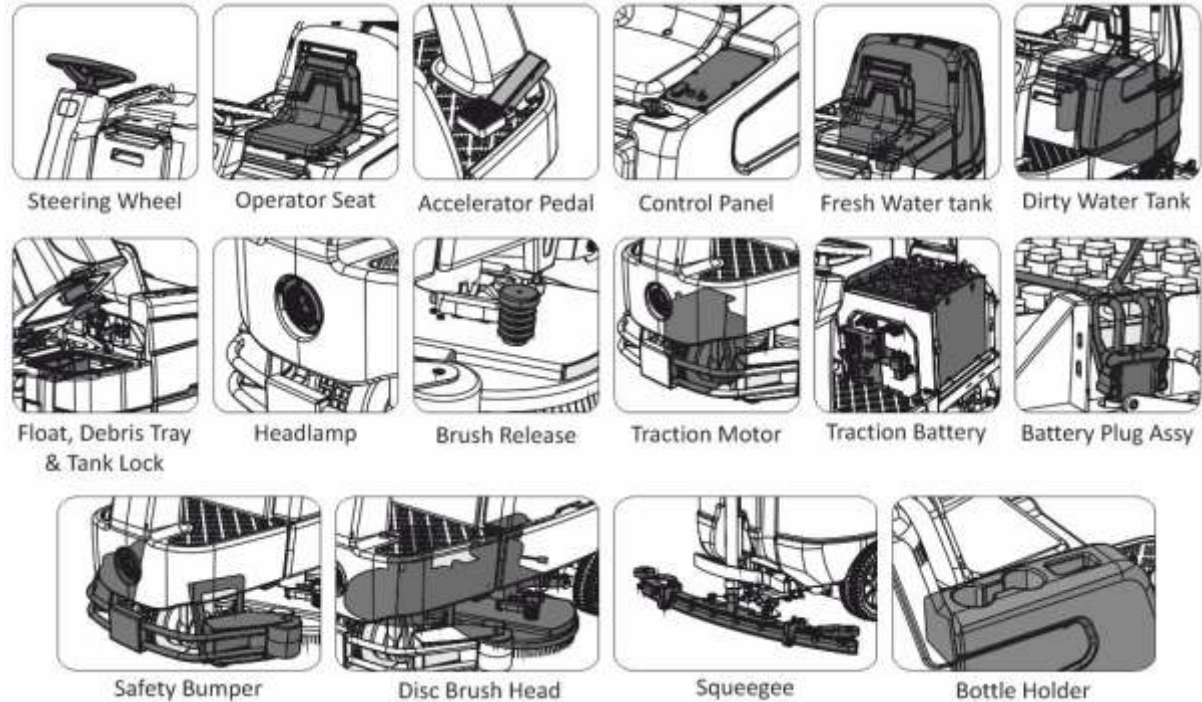
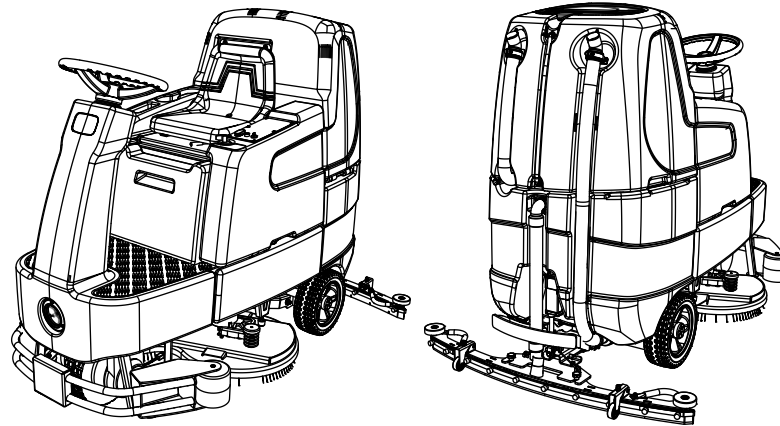

Decals on the machine

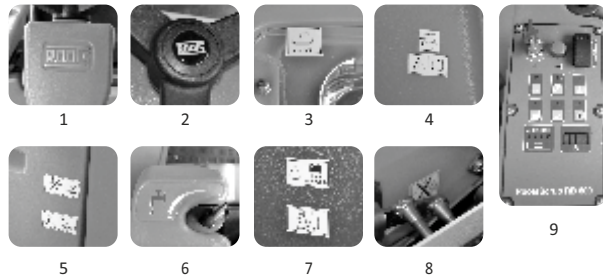
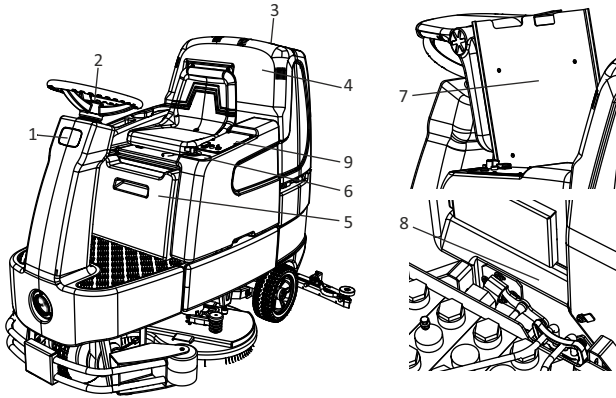

1. Roots - Silvergrey
2. Roots - Dome
3. Fresh water filling
4. Remove key/Read instruction manual
5. Do not wash with high pressure/Max inclination
6. Water flow control
7. Read battery instruction
8. Hand crush warning
9. Control panel

Principle of operation

A squeegee and suitable brushes or pads are required for wet cleaning of hard floorings. The rotating brushes (1) scrubs the floor thoroughly, removing dirt, by cleaning agent supplied from the fresh water tank (2) thereby cleaning the floor. The soiled water is drawn during the same cycle through the squeegee (3) and fed into the dirty water tank (4). Thus, the floor can be walked on immediately after it is dry and clean.

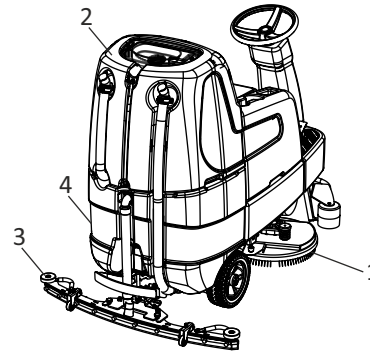

Useful tips

- Prior to wet cleaning, it is necessary to clean the floor. This way, not only is the cleaning efficiency improved, but wear of the brush is also substantially reduced.
- If floors are particularly dirty or if wax has to be removed (basic cleaning); the floor must be treated twice.
- During the first cycle, the floor is scrubbed with the cleaning agent selected according to the degree of dirt encountered, the squeegee remaining lifted.
- Allow the cleaning agent to act on the floor for approx. 5 or 10 minutes, complying with the manufacturer's instructions.
- Scrub the floor once again while the squeegee is lowered.
- Too much foam indicates excessive dosage or improper suitability of detergent for the existing kind of dirt.

- Detergent particles contained in the soiled water that are not used will cause formation of foam.
- Instructions for dosage are given on the detergent tank and must ideally adhere to manufacturer's recommendations.
- The ideal type of detergent and the perfect dosage applicable to it will come through sustained use of the machine.



Comply with instructions for correct dosage of detergent. Correct dosage will help optimize costs and also minimize impact on the environment. Too much foam can affect the performance of the machine.

OPERATING AND INDICATOR ELEMENTS

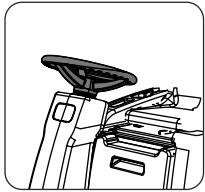

1. Steering Wheel-
Used to steer the machine.

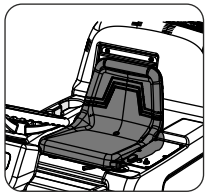

2. Operator's seat
Adjust the driver's seat longitudinally as follows:
- Push lever to the side and displace the seat as required, then let the lever catch into place again.

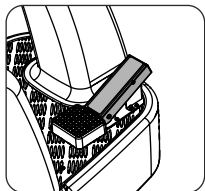

3. Accelerator Pedal
Used to propel the machine forward or backwards.

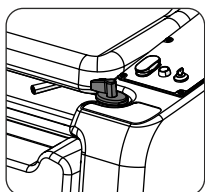

4. Water Flow Control
Used to change the water flow from minimum to maximum.

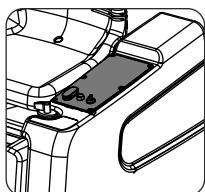

5. Control Panel-
Houses all the controls of the machine.

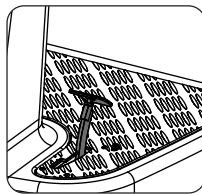

6. Brake Pedal
Used to slow/stop the machine.

Control panel switches in detail -

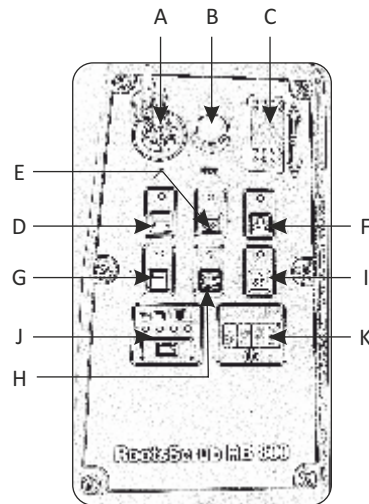

- A. Key Switch (On/Off)
- B. Horn Button
- C. Direction Selector (Forward/Backward)
- D. Brush Motor (On/Off)
- E. Suction Turbine (On/Off)
- F. Extra Pressure
- G. Soiled Water Tank Full Indicator Lamp
- H. Working Lamp (On/Off)
- I. Drive Motor Malfunction Warning Lamp

- J. Battery Charge Status Indicator Lamp
- K. Hour meter & Error Code Display

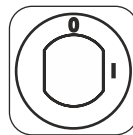

A. Key Switch-
Turns the electrical system On/Off.



B. Horn Button-
Actuates the electric horn.

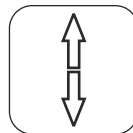

C. Direction Selector-
Selects the direction of travel.



D. Brush Motor (On/Off)-
Turns the Brush motor On/off
Lowers & Raises the brush head according to the operation.

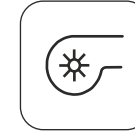

E. Suction Turbine (On/Off)-
Turns the Suction Turbine On/Off.
Lowers & Raises the squeegee according to the operation.



F. Extra Pressure-
Increases the brush pressure to 50 kg max for heavy soiling.

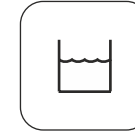

G. Soiled water tank full indicator lamp-
Glowes when the soiled water tank is full.

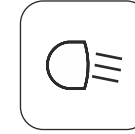

H. Working Lamp (On/Off)-
Toggles the working lamp On or Off

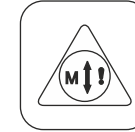

I. Drive Motor Malfunction warning lamp-
Glowes when there is an error in the drive motor or controller.

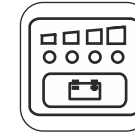

J. Battery Charge status indicator lamp-
Shows the status of the battery.

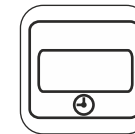

K. Hour meter & Error Code Display-
Displays the total hours of machine use and any error in the electronic module.

Disc Brush Head

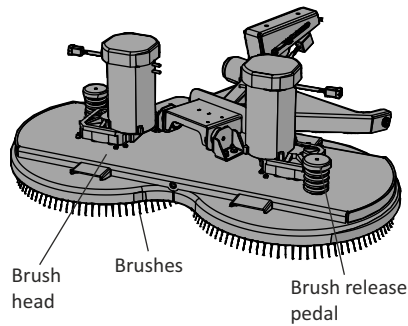

Cleaning the disc brushes

Clean the disc brushes on the brush head daily or as necessary.

1. Raise the brush head.
2. Press the brush release pedal downwards and remove the disc brushes to clean them.

 **Do not use harsh acids or chemicals to clean the disc brushes.**

Installation of disc brushes

Check the disc brushes on the brush head weekly for signs of wear. In case of wear the disc brushes must be changed.

1. Raise the brush head.
2. Press the brush release pedal downward and remove the disc brushes.
3. Slide a new disc brush under the brush head and press it into the catch using both hands.

 **Switch off machine before changing brushes. Care should be taken while mounting brushes. Do not stand on the brush head.**

Squeegee

The squeegee is used to extract the dirty water from the floor.

Parabolic

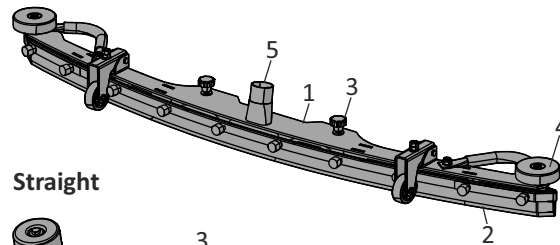

Straight

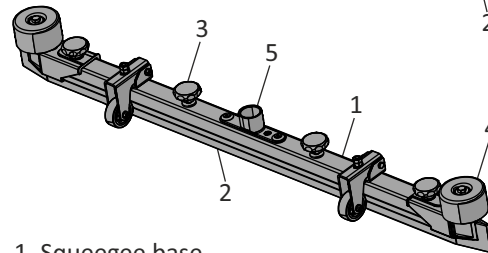

1. Squeegee base
2. Squeegee lip
3. Knob
4. Deflector roller
5. Suction port

Replacement of squeegee lips

Check the inner and outer lips on the squeegee daily for signs of wear. The lips can be used four times by flipping it 90° and reused.

1. Raise the squeegee.
2. Pull the suction hose from the squeegee, unscrew the knobs and remove the squeegee.
3. Loosen the fastening knobs/strips and remove the lip. Turn or replace the lip if necessary. Follow the same for the inner lip also.

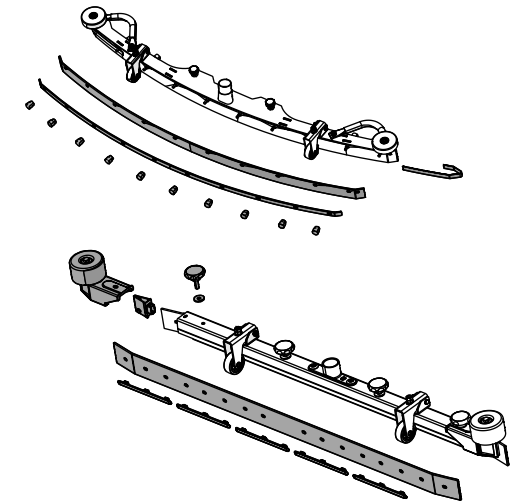

Clean the squeegee before starting the work cycle every time. Do not stand on the squeegee.

Cleaning the squeegee

Check the squeegee daily and clean as necessary. To clean the squeegee, raise it, disconnect it from the suction hose, loosen the knobs and remove the squeegee. Wash the squeegee under clean running water.

Driving the machine

The machine is powered by a powerful traction motor.

Starting-

To propel the machine press the accelerator pedal in downward direction.

Stopping-

To stop or slow the machine release the accelerator pedal (Pedal returns to its initial position). Press the brake pedal to slow or stop the machine.

Proceed to the first driving trails on a clear training ground until the driver is acquainted with the elements and their functions.

- Before leaving the machine make sure to remove the key.
- Because of skidding hazard drive at reduced speed on wet grounds and when turning.
- Drive slowly on downhill, turning, wet grounds, ramps and on uneven surfaces.
- Do not drive the machine in flooded areas. Risk of damaging the traction motor.
- Never make sharp maneuvers while driving.
- Do not adjust the seat while driving the machine.

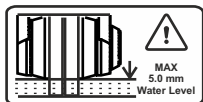

Maximum inclination of 10° is only allowed.

Maximum water wading of 5.0 mm is allowed.

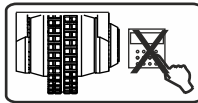

Do not tamper the traction motor controller. Risk of damaging the motor.

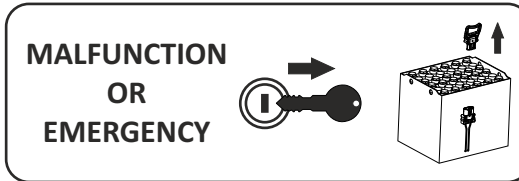

In case of an emergency or malfunction - switch of key and disconnect battery plug.

Start of cleaning

- To fill clean water in the fresh water tank insert the water hose into the fill port.
- Add required amount of recommended cleaning agents to the water.
- Move the machine to the area to be cleaned.
- Switch on key "A".
- Operate water lever to select the desired amount of flow.
- Press "D" to lower the brush head - brush head lowers and brushes rotate.
- Press "E" to start suction turbine - suction turbine starts and squeegee lowers.
- Operate "C" to forward position.
- Drive immediately or the brushes will leave traces on the floor.
- Commence cleaning operation of the area.

DIRTY AND FRESH WATER TANKS

Fresh water tank

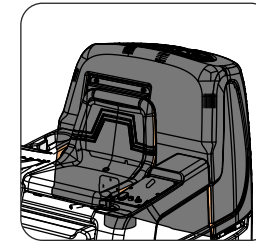

The fresh water tank has a capacity of 120 liters of water.

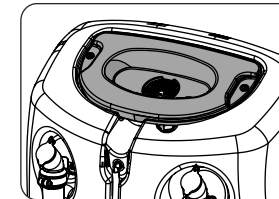

Place the water hose into the fill port to filter and fill the tank.

Do not fill water beyond a temperature of 50°C.

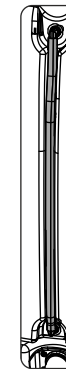

Fresh water tank indicator hose.

Dirty water tank

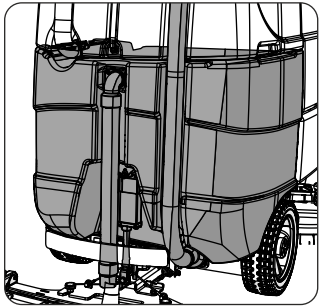

The dirty water tank has a capacity of 120 liters.

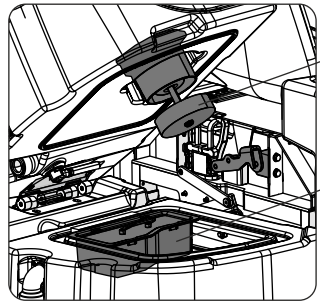

Float

Collection Tray

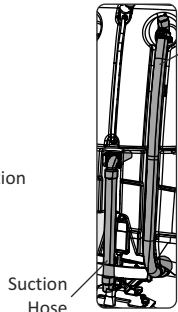

Drain Hose

Suction Hose

End of cleaning

- Press “D” to switch off brush head.
- Close the water flow.
- Run the machine to collect the remaining water.
- Press “E” to switch off suction turbine and raise squeegee.
- Drive the machine to the waste disposal area.
- Unhook the drain hose and dump the dirty water to the drain.



Do not drain the soiled water into the environment.

- Remove the collection tray and clean with fresh water.
- Clean the dirty water tank with clean water.



- Do not clean the machine by means of a vapor jet or a high pressure cleaning equipment. Clean the brush head with a water hose (pressure: 5 to 6 bar max.) and from the bottom only.



- Do not direct the water jet into any opening, slots, on electronic modules, control panels or sealing.**
- Do not use harsh chemicals to clean the machine.**
- Wipe the machine with a damp cloth after usage.**

Remove the squeegee from the machine and clean the lips before the next operation.

Electrical System

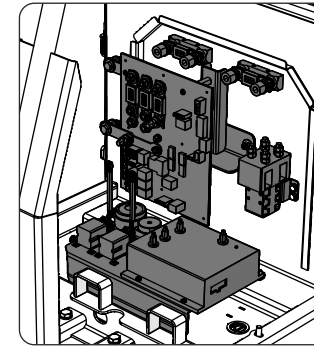

Main control module & Traction motor controller

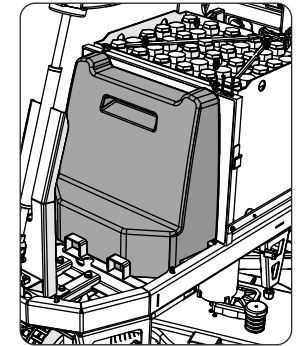

Cover electrical module

The electrical system houses the main control module and the traction motor controller.

- Do not open the cover of the electrical module.**
- Remove key before carrying out any electrical work.**
- During battery top up ensure that the cover electrical module is closed securely.**
- Never open the cover electrical module in dusty areas.**
- DO NOT TAMPER WITH THE ELECTRICAL MODULE OR THE CONTROLLER.**
- Do not dispose the replaced electrical/electronic components in to the environment.**

Service Display

The hour meter holds the service display. Upon turning on the following are successively displayed:-

- software version is displayed	- battery type is displayed	- total operated hours is displayed
V 02	LA	0000

Fuse Error Codes

Error Code	Description	What to do ?
EF 01	F1 Fuse blown	Brush motor 1 is overloaded. Rectify the cause and replace the fuse.
EF 02	F2 Fuse blown	Brush motor 2 is overloaded. Rectify the cause and replace the fuse.
EF 03	F3 Fuse blown	Suction turbine is overloaded. Rectify the cause and replace the fuse.

If a malfunction occurs during operation, e.g. a defective fuse, a 4-digit number appears in the hour meter display with 4 dots flashing and a buzzer sounding. This 4- digit number advises the technician in detail on the last error found.

Other Error Codes

(For RMCL service engineers reference only)

Error Code	No.of Alarm LED Blinks	Description	What to do ?
A 1	1	FNR switch(-S3) at forward position when power-on	Put the accelerator pedal to zero and set the FNR switch in neutral at power-on.
A2	2	FNR switch(-S3) at reverse position when power-on	Put the accelerator pedal to zero and set the FNR switch in neutral at power-on.
A3	3	Potentiometer(-S6) in the accelerator pedal fault.	Check the potentiometer (-S6) wires
A4	4	Potentiometer(-S6) out of neutral position at power on	Move the potentiometer to neutral position or,if it is in neutral position already, calibrate the speed reference. Wait few minutes and check the motor current. If it is high rectify the cause and then use.
A5	5	Thermal protection	
A6	6	Controller power stage damaged	Change the drive controller.
A7	7	Over current 1: short circuit	Check the motor wires: if OK, and the controller repeats this alarm, change it
A8	8	Over current 2: short circuit	Check the motor wires: if OK, and the controller repeats this alarm, change it
A9	9	Under voltage	Check the battery's charge
A10	10	Over voltage	Battery voltage upper than 45V : Check the battery
A11	11	Overload protection	Check whether the traction motor brake functions properly. If not replace brake immediately and use. Check the motor working current.
A12	12	Disable switch on	Check the parking brake limit switch (if used). This alarm will reset by resetting the keyswitch (-S1).
A13	13	Key-off sequence detected	Check the key switch(-S1) connections
A14	14	E ² prom fail	Check your settings: if the controller repeats this alarm, change it

Maintenance Work

Compliance with our recommendations concerning maintenance work will give you the certitude always having a machine at your disposal, which is ready to work and in good operating condition. Please contact your local distributor; the people there will be glad to perform that work for you.

- Well trained personnel and genuine spare parts are at your disposal.
- In case of any inquiries or orders for spare parts, please always quote the machine's serial number mentioned on the nameplate.
- The name plate is fixed in the rear side of the machine.
- When cleaning or servicing the machine, and when replacing any parts, shut off the machine and on principle disconnect the power plug from the power supply.
- For reasons of safety during cleaning and/or maintenance work in or on the tank, the tank lid - when lifted - must be secured so as to prevent accidental closing or tilting down.
- The machine may be taken into operation only if all guarding devices are fitted and in protective position. As far as possible, cleaning should not be done by hand, but using appropriate tools or equipment.
- Maintenance and repair work may be carried out only by means of suitable tools and by the people trained in the factory - for reasons of safety, only genuine spare parts may be used.

Maintenance Schedule

Maintenance Table	Service Hours			
	daily	every 50	every 200	every 500
Recharge batteries according to charger unit instructions	●			
Empty and clean dirty water tank	●			
Check condition of squeegee lips	●			
Check squeegee for foreign particles taken and clean if required	●			
Clean filter in fresh water tank	●			
Check battery poles and apply grease if required	●			
Check tight fitting and condition of suction hose between squeegee and dirty water tank		●		
Check squeegee lips for wear and turn or replace if required		●		
Check brushes and water retaining ring for tight fitting and condition and replace if required		●		
Check function of float		●		
Check rotational direction of the brushes		●		
Check function of brake		●		
Check squeegee holder and castor roller, re-adjust if required			●	
Check fresh water supply to the brushes		●		
Clean traction motor from carbon dust and check the accessible carbon brushes for smooth running and condition, replace if required				●
Clean electro-motor from carbon dust and check the accessible carbon brushes for smooth running and condition, replace if required				●
Grease steering pinion and gear ring				●
Check joints at squeegee holder and grease if required				●

Greasing Points

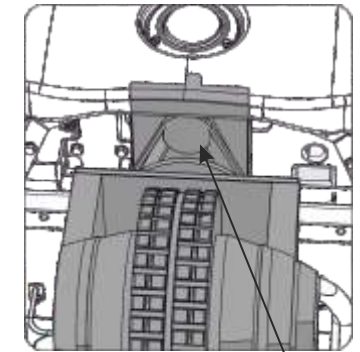

Greasing point

Problem	Cause	Remedy
<i>No power - nothing works</i>	Faulty power switch	Contact service
	Battery need to be recharged	Recharge battery
	Faulty battery	Replace battery
	Loose battery cable	Tighten loose cable
	Main fuse blown	Rectify the cause & Replace the fuse
<i>Brush motor does not work</i>	Accelerator pedal is not depressed	Depress accelerator pedal
	Main fuse blown	Rectify the cause & Replace the fuse
	Faulty brush motor or loose cable	Contact Roots service
<i>Suction turbine does not work</i>	Faulty suction turbine switch	Replace switch
	Suction turbine fuse blown	Replace the fuse
	Faulty suction turbine	Contact Roots service
	Carbon brushes worn	Contact Roots service
<i>Insufficient water flow</i>	Water tank low	Refill fresh water
	Flow lever turned to stop	Turn lever more to open
	Water line clogged	Remove and blow with compressed air
	Water valve clogged	Remove and clean
<i>Poor water recovery</i>	Dirty water tank is full	Empty dirty water tank
	Suction hose is clogged	Remove debris
	Squeegee is clogged	Remove debris
	Squeegee lip is worn	Rotate or replace lips
	Faulty vacuum hose	Contact service

Problem	Cause	Remedy
<i>Poor water recovery</i>	Tank gasket faulty	Contact service
	Drain hose leak	Hook up drain hose and close
	Suction turbine faulty	Contact service
	Battery charge low	Recharge battery
<i>Tires noisy</i>	Bearing dry	Grease bearings
	Faulty hubs	Contact service
<i>Poor traction</i>	Excessive brush pressure	Reduce pressure
	Worn traction tire	Replace tire
	Heavy soap concentration	Contact service
<i>Short run time</i>	Battery run down	Charge battery twice
	Battery still down	Contact service
	Battery low on water	Refill with distilled water
	Battery over cycled	Contact service

Do's

1. Charge the batteries after it has been completely discharged.
2. Charge the batteries only in a well ventilated area.
3. Use only clean water to fill the fresh tank.
4. Fill fresh water till the marked level only.
5. Clean the fresh water filter after each cleaning cycle.
6. Empty the dirty water at a specified draining area.
7. Clean the dirty water tank and collection tray after each cleaning cycle.
8. Clean the suction float assembly if any dirt is noticed.
9. Clean the squeegee after every cleaning cycle.
10. Use only recommend cleaning solutions.
11. Wipe the machine at the end of the day.
12. Drive at a slow speed on ramps and uneven surfaces.
13. Use only recommended brushes for the specified floors.
14. Park the machine in a covered dry place.

Don't's

1. Do not charge the batteries between cleaning cycle.
2. Do not use the machine for transporting goods or persons.
3. Do not modify the machine.
4. Do not fill water beyond 50°C.
5. Do not use harsh or acidic solutions.
6. Do not empty the dirty water in a habitable area.
7. Do not drive with the fresh water tank open.
8. Do not stand on the brush head and squeegee.
9. Do not park the machine on ramps or slopes.
10. Do not place any objects on the battery while charging.
11. DO NOT TAMPER WITH THE ELECTRICAL CIRCUITS.
12. Do not open the electrical module cover.
13. Do not adjust the drive motor controller.
14. Do not clean the machine with a high pressure cleaning system.
15. Do not abuse the machine beyond its operable limit.
16. Do not mix brushes and use.
17. Do not park the machine by exposing it to the natural elements.
18. Do not use the machine to tow or push other equipments.
19. Do not over fill the distilled water in the battery.

Before using the machine

Battery plug coding

All battery plugs at machines, batteries and battery charger units have to be coded with the colored coding pins according to the battery type and the charger unit plugs are/will be seteristic curve such that a modification of the curve (in relation to the battery type) requires changing of the plug coding nominal voltage.

Plug case of charger units :

Grey for fluid-filled batteries, Green for maintenance-free Gel batteries

Plug case of machine :

Yellow for both battery types

Socket case of battery: Grey for fluid-filled batteries :
Green for maintenance-free

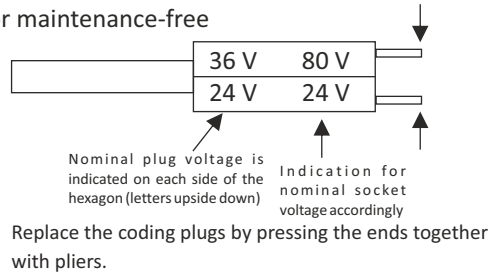

Press together for removal

Insert coding plug such that the nominal voltage inscription is visible through the case window. Socket and plug only with the same nominal voltage. The following three conditions have to be met:

- 1) Voltage coding must be the same for all sockets and plugs.
- 2) Coding pin colour in the machine = yellow
- 3) Coding pin colour in the charger unit = the same as for the battery plug according to battery type.



Open the seat console of the machine before performing charging operations.



Before first operation of the machine, fully charge the battery with an initial charging procedure and comply with the operating instructions of the charger as well as with those of the battery manufacturer. Roots cannot be held liable for damages resulting from the fact that the initial charging has not or insufficiently been done.

Coding system in the charger unit for fluid-filled batteries

Example 24V Battery System

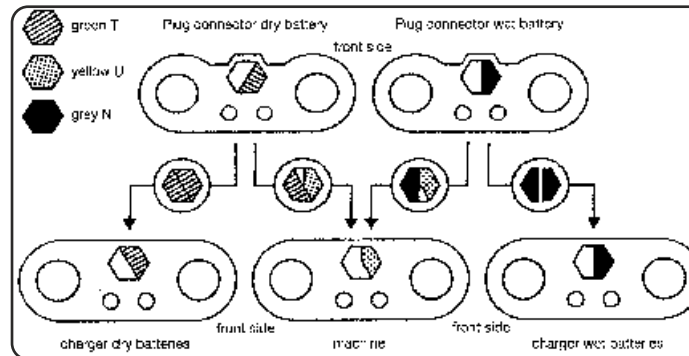

Charging procedure for traction block batteries

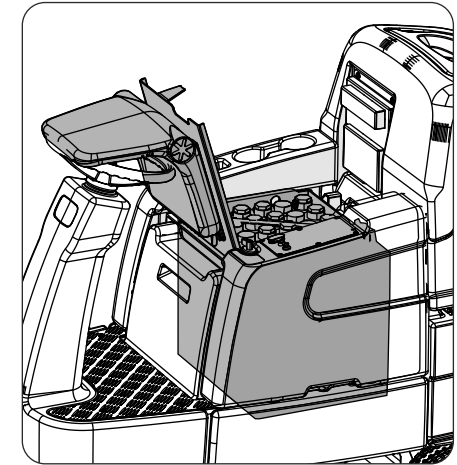

- Drain both the tanks
- Move machine near charger location
- Switch Off Key
- Remove key
- Tilt operator seat forward completely
- Disconnect the battery plugs and connect them to the charger supplied with the machine.

- **Make sure to connect the charger to the specified voltage and frequency.**
- **Ensure that the seat cover is completely open.**
- **Do not place any objects on the battery.**



Charge the batteries in a well ventilated area. Do not tamper with the charger settings.

Safety symbols for traction battery system



The above instructions have been established for your safety and have to be strictly observed.



-Observe the instruction which must be mounted clearly at the charging point!



-No Smoking!
-No naked lights, embers or sparks in the vicinity, risk of fire and explosion!



-Wear protective goggles and protective clothing when working on the batteries!



-Do not tilt the battery!
-Only use certified hoisting and transport equipment.



-Keep children away from batteries



-Any splashes of acid in the eyes or on the skin must be rinsed thoroughly with plenty of clear pure water.
-Then consult a doctor immediately!



- Risk of fire explosion, avoid short circuits!
- **Caution!** Metal components in the battery cells are always under voltage, never place any foreign items or tools on the battery!



-Electrolyte is highly corrosive!



-Charge in a well-ventilated area



-Do not throw in garbage!

Traction Batteries (LA)

1. Initial Checking-

Check the battery to ensure that it is in perfect mechanical condition. All screwed unions within the circuit must be tightened to ensure reliable contacts. Machine cables and charging cable are to be connected to the correct poles of the battery otherwise battery and charger can be damaged.

2. Discharging-

Ventilation openings may not be covered or closed. Electric connections (e.g-plugs) may be connected or disconnected only when the machine is in off condition. Discharge batteries must be recharged immediately and may not remain in discharged condition. This also applies to only partially discharged batteries. The battery may only be connected up to the allocated battery charger certified for the particular battery size, to avoid overload on the electric current Maintenance Free Batteries have low gassing properties but are not completely free of gassing. The battery is to be connected with the correct poles (plus to plus and minus to minus) to the disconnected battery charger. The battery charger should then be switched on.

During the recharging procedure, the temperature in the battery increases by approx. 10 °C. For this reason, the recharging procedure may not be started unless the temperature is below 35 °C.

Before recharging the battery, the temperature should be at least 15 °C, otherwise the battery will not be correctly. If the temperatures are constantly greater than 40 °C or lower than 15 °C, temperature-dependent constant voltage regulation of the battery charger will be necessary.

3. Temperature-

The battery temperature of 30 °C is rated temperature. Higher temperatures shorten the service life and lower temperatures reduce available capacity. 45 °C (51 °C for AGM) is the limit temperature and is not tolerable as operating temperature.

4. Electrolyte-

The electrolyte is sulphuric acid. The density of the electrolyte cannot be measured. Use the recommended electrolyte to top up.

5. Maintenance-

Daily maintenance- Recharge the battery every time it has been discharged.

Weekly maintenance- Visual inspection after recharging for signs of dirt and mechanical damage.

Maintenance to be carried out every three months

After fully recharging and following a standing period of at least 5 hours, the following must be measured and Recorded: – total voltage / – individual voltage

If noticeable changes are detected compared to previous measurements, or differences between the cells or block batteries, the customer service should be called for testing or repair.

6. Care-

The battery must be kept clean and dry to prevent creeping current. Any liquid in the battery container must be extracted and disposed of according to regulations.

7. Storage-

If batteries are out of operation for longer periods, they should be stored in fully charged state in a dry, frost free room.

In order to ensure that the battery is ready for operation at any time, it can be recharged according to one of the following methods:

1. Full recharge every three months. When a consumer is connected up (e.g. measuring or controlling devices), it may be necessary to recharge the battery every two weeks.
2. Maintenance recharging at a recharging voltage of 2.25 V x number of cells. The storage period is to be taken into account for the service life.

8. Faults-

The customer service should be called immediately when any faults are discovered in battery or battery charger.

Lead Acid (LA) Battery Instructions

- Kindly ensure that the Warranty certificate of the battery is available at your end.
- Kindly read the Do's & Don't's of the battery, understand and follow.
- Check the electrolyte level before charging and top it up with battery grade distilled water if required.
- Match the battery to the correct charger.
- Keep the battery well ventilated while charging.
- Charge the battery immediately after it is discharged completely.
- Keep all inter cell connections and bolted terminals tight and covered with petroleum jelly.

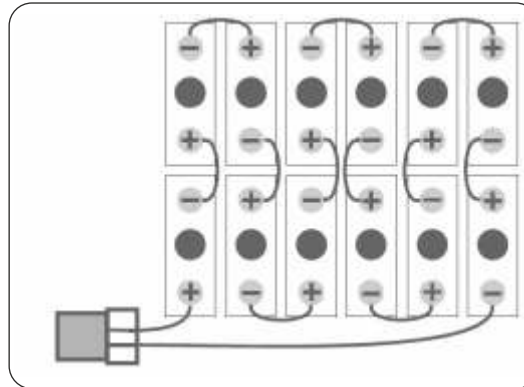
Battery connection diagram**Battery and charger specification****Battery:**

Type: Traction block battery

Rating: 24V, DC, 320Ah

Charger:

Type: External type

Rating: 230V, AC, 50-60Hz

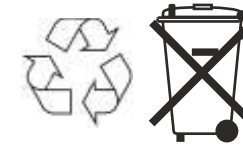
Disposal of batteries

Old batteries with this sign are recyclable economic goods and should be brought back into the recycling process. Old batteries which are not brought back into the recycling process, have to be dealt with as dangerous materials under the observance of all regulations.

ILLUSTRATED PARTS LIST

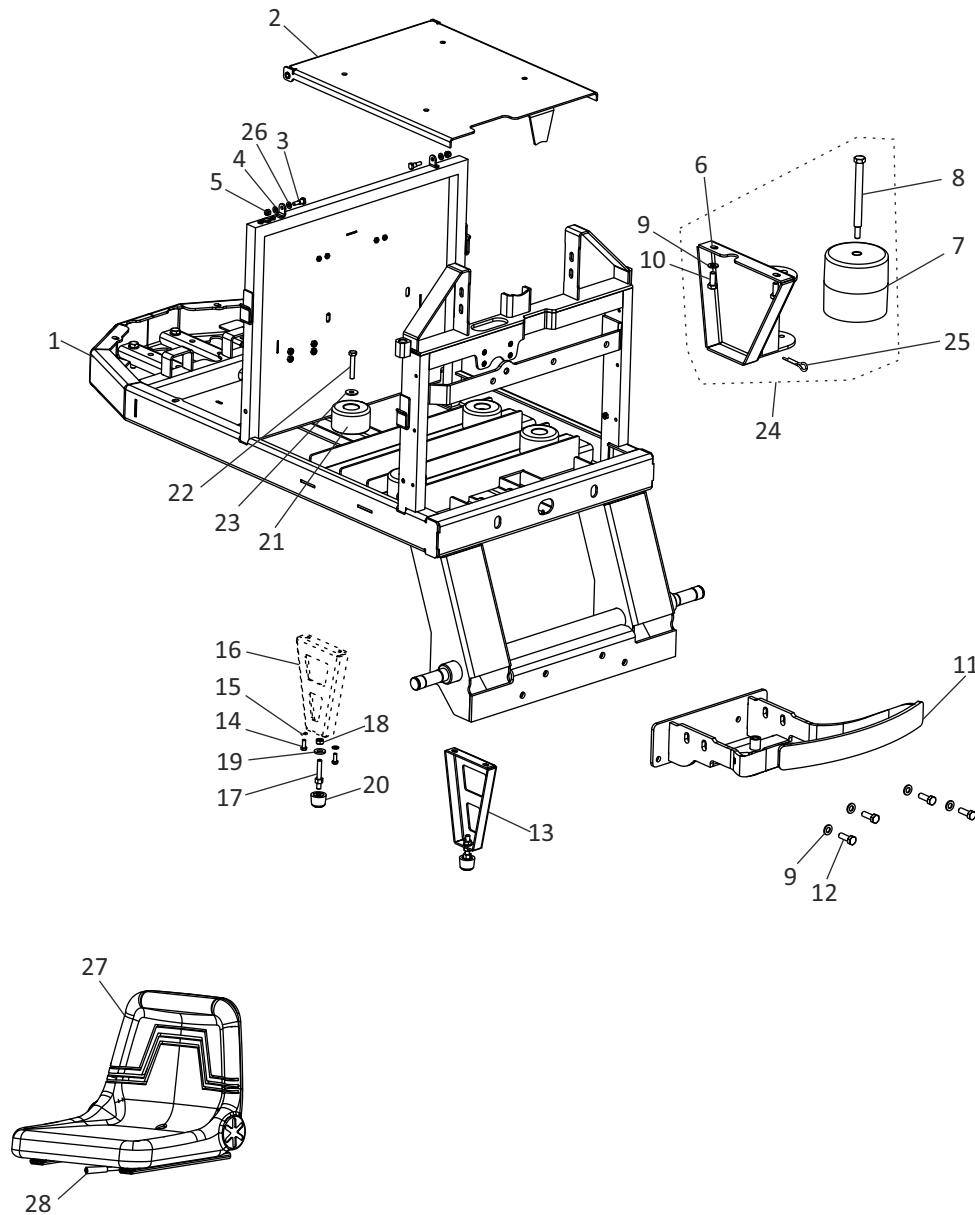

REF. NO	PART NO	DESCRIPTION	QTY
1	558100186-00	ASSY CHASSIS WELDMENT	1
2	558100046-00	SEAT MTG PLATE WELDMENT	1
3 (RB800)	552230012-00	HEX SOC HEAD CAP SCREW STEEL - M6X20	2
3 (RB950)	553100143-00	PIN SEAT HINGE	2
4	552350025-00	WASHER - STEEL-6.4X12.5X1.6	2
5	552480006-00	HEX NYLOCK NUT-STEEL - M6	2
6 (RB800)	558100251-00	BRACKET DEFLECTOR ROLLER MTG WELDMENT	1
7 (RB800)	553100138-00	DEFLECTOR ROLLER BRUSH HEAD	1
8 (RB800)	558100222-00	DEFLECTOR ROLLER PIN WELDMENT	1
9	552350018-00	WASHER STEEL-10.5X20X2	6
10	552020022-00	HEX HEAD SCREW-STEEL 8.8-M10X25	2
11	558100048-00	BUMPER REAR WELDMENT	1
12	552020023-00	HEX HEAD SCREW-STEEL8.8-M10X30	4
13	558100249-00	BRACKET ASSY BH SUPPORT	2
14	552020007-00	HEX HEAD SCREW-STEEL8.8-M6X16	4
15	552350012-00	WASHER -STEEL-6.4X18X1.6	4
16	558100224-00	BRACKET BH SUPPORT	1
17	553100284-00	STUD BOOT BH	2
18	552170012-00	HEX NUT-STEEL GR.8-M8	4
19	552360013-00	WASHER SS304-8.4X16X1.6	4
20	558100086-00	BOOT ASSY BH SUPPORT	2
21	553530713-00	DEFLECTOR ROLLER	5
22	552040010-00	HEX HEAD SCREW-SS304-M8X40	5
23	552350017-00	WASHER STEEL-8.4X24X2	5
24	558100035-00	ASSY DEFLECTOR ROLLER	1
25	552330007-00	COTTER PIN 3.2X35	1
26	553350529-00	SAPCER ROPE CT	2
27	558100155-00	OPERATOR SEAT	1
28	553420049-00	KNOB SEAT LEVER	1

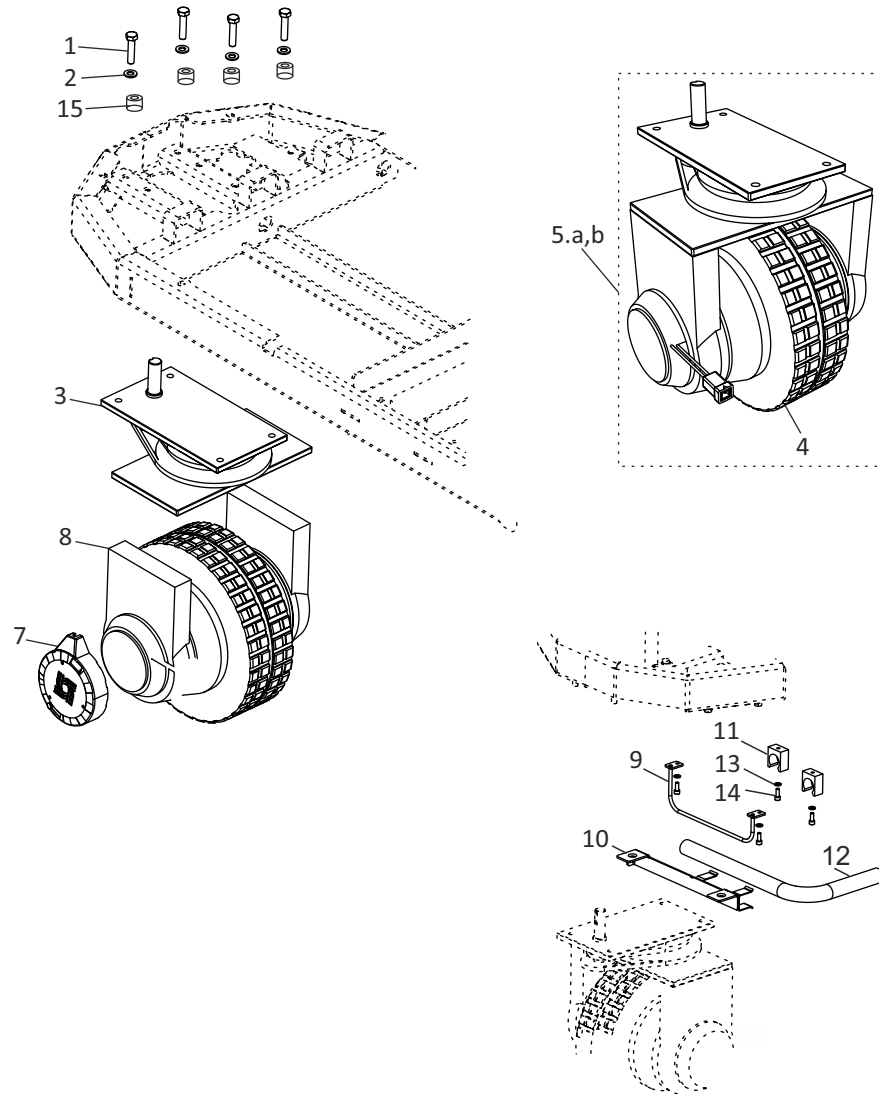

REF. NO	PART NO	DESCRIPTION	QTY
1	552020100-00	HEX HEAD SCREW-STEEL8.8-M10X55	4
2	552350018-00	WASHER - STEEL-10.5X20X2	4
3	553100275-00	STEERING MECHANISM	1
4	553100348-00	TYRE - DRIVE MOTOR	1
5.a	558100332-00	ASSY DRIVE MOTOR W/O BRAKE	1
5.b	558100228-00	ASSY DRIVE MOTOR W/O BRAKE - MTRMP11	1
6	553100344-00	CARBON BRUSH KIT DRIVE MOTOR	1 Set
7	553100422-00	BRAKE COVER	1
8	553100274-00	DRIVE MOTOR RB 800	1
9	558100177-00	MOUNTING BRACKET WELDMENT	1
10	558100178-00	HOSE FITTING WELDMENT	1
11	552670129-00	HOSE CLAMP 1 INCH	4
12	551520024-00	PVC FLEXIBLE HOSE	1
13	552350011-00	WASHER STEEL-6.4X12.5X1.6	4
14	552230011-00	HEX SOC HEAD CAP SCREW-STEEL-M6X16	4
15	553100783-00	SPACER DRIVE MOTOR	4

NOTE - Item No. 6 is not showed in the fig.

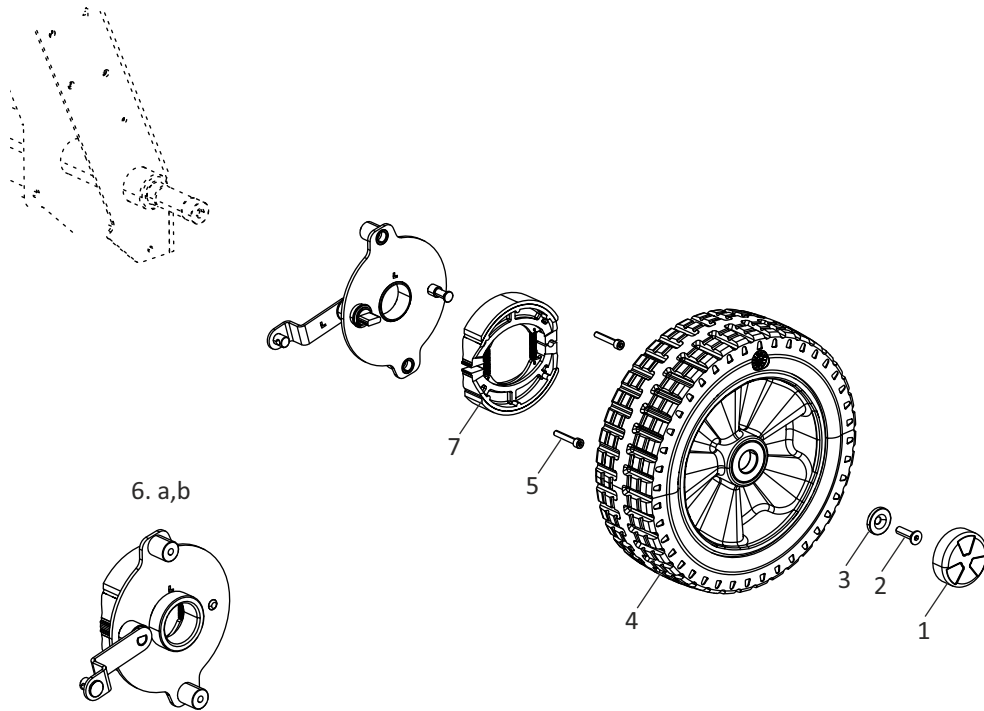

REF. NO	PART NO	DESCRIPTION	QTY
1	553100268-00	WHEEL CAP	2
2	552220014-00	HEX SOC CSK HD SCREW SS304 - M8X30	2
3	553350019-00	WASHER WHEEL	2
4	558100037-00	ASSY - REAR WHEEL	2
5	552230034-00	HEX SOC HEAD CAP SCREW STEEL - M6X35	4
6.a	558100342-00	BRAKE ASSY LH	1
6.b	558100343-00	BRAKE ASSY RH	1
7	553100630-00	BRAKE SHOE - 130	2

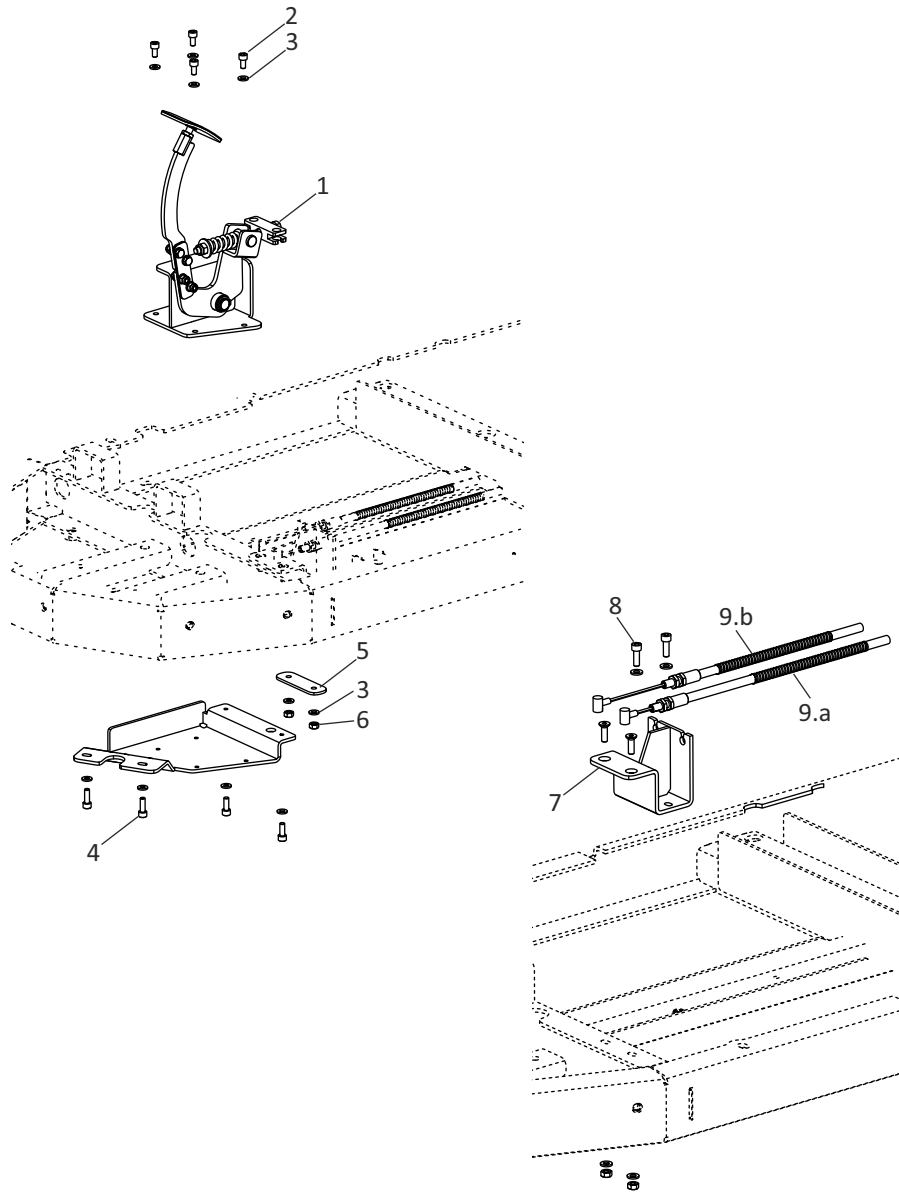

REF. NO	PART NO	DESCRIPTION	QTY
1	558100338-00	BRAKE PEDAL ASSY	1
2	552230009-00	HEX SOC HEAD CAP SCREW STEEL - M6X12	4
3	552350011-00	WASHER STEEL - 6.4X12.5X1.6	12
4	552230015-00	HEX SOC HEAD CAP SCREW STEEL - M6X18	6
5	553100636-00	SUPPORT BRAKE ROPE MTG BKT	1
6	552170009-00	HEX NUT STEEL - M6	4
7	558100339-00	ROPE HOLDER BRACKET WMT	1
8	552220009-00	HEX SOC CSK HEAD SCREW STEEL - M6X20	2
9.a	558100346-00	BRAKE CABLE ASSY - LH	1
9.b	558100347-00	BRAKE CABLE ASSY - RH	1

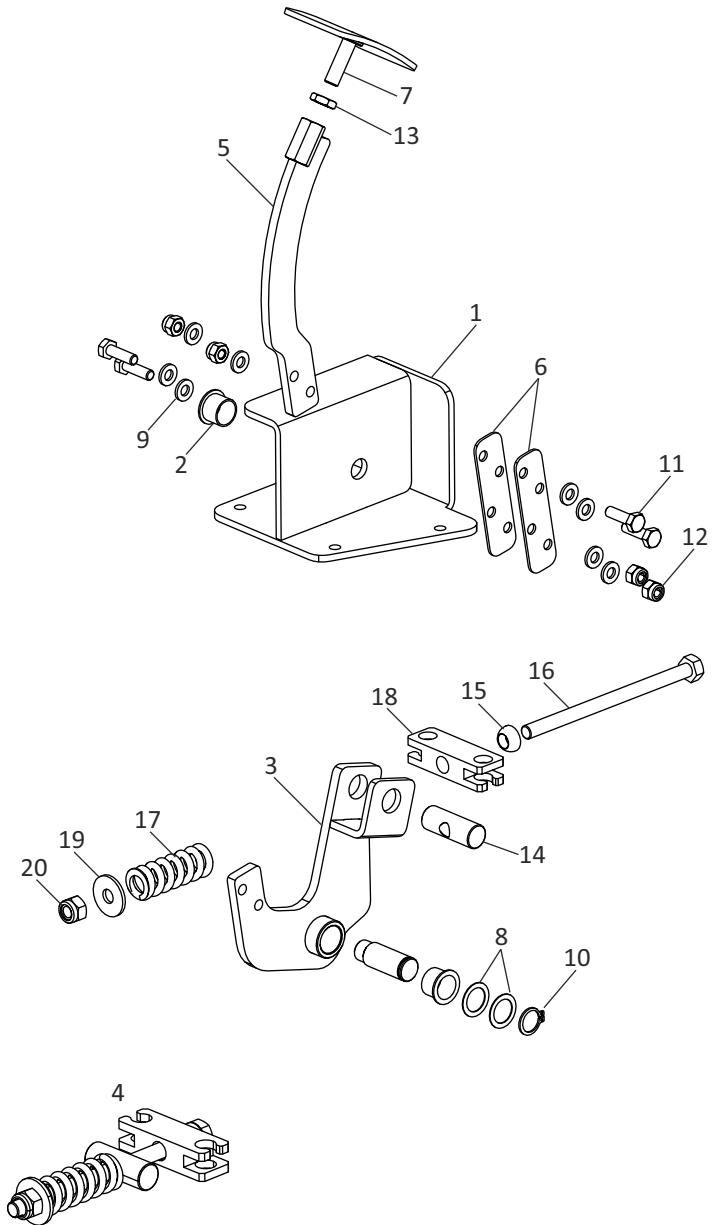

REF. NO	PART NO	DESCRIPTION	QTY
1	558100334-00	BRAKE PEDAL HOLDER WELDMENT	1
2	5535310276-00	LINEAR BEARING - 14X11	2
3	558100335-00	BRAKE PEDAL - WELDMENT	1
4	558100337-00	LOAD ASSY BRAKE PEDAL	1
5	558100336-00	BRAKE LEVER WELDMENT	1
6	553100615-00	PLATE SPRING	2
7	558100045-00	PLATE WELDMENTR ASSY	1
8	553230008-00	WASHER - 14.2X20X0.5	2
9	552350011-00	WASHER STEEL - 6.4X12.5X1.6	8
10	552670166-00	CIRCLIP - A 13	1
11	552020008-00	HEX HEAD SCREW STEEL - M6X20	4
12	552480006-00	HEX NYLOCK NUT - STEEL - M6	4
13	552250004-00	HEX LOCK NUT STEEL - M8	1
14	553100637-00	PIN PIVOT - CABLE	1
15	553510258-00	SPACER BRAKE	1
16	553510245-00	SPECIAL BOLT	1
17	553100617-00	SPRING - BRAKE PEDAL	1
18	553510257-00	LINK - BRAKE CABLE	1
19	552350017-00	WASHER STEEL - 8.4X20X2.0	1
20	552480008-00	HEX NYLOCK NUT STEEL - M8	1

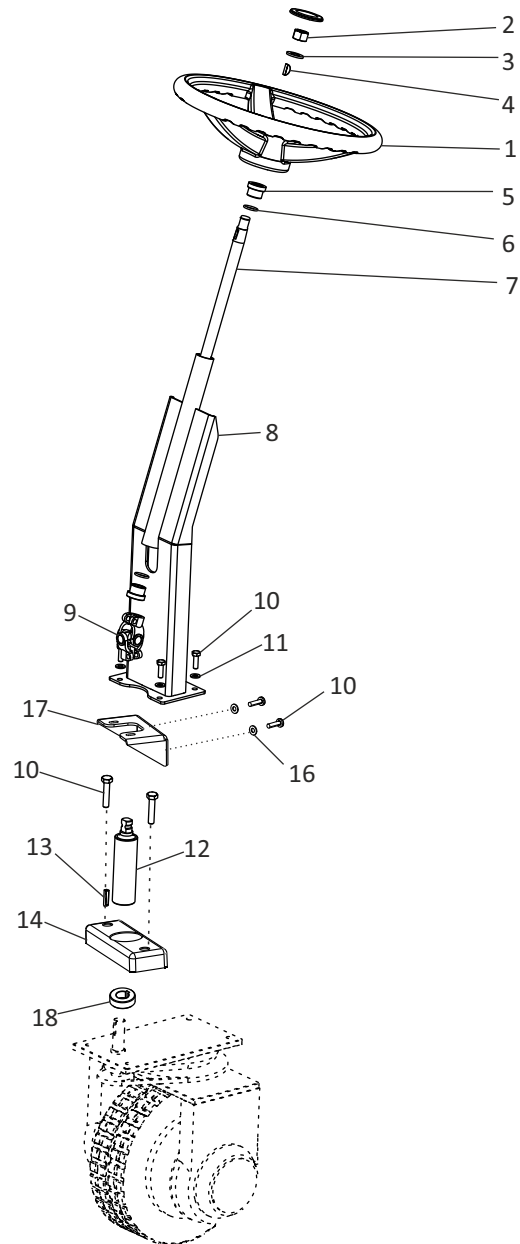

REF. NO	PART NO	DESCRIPTION	QTY
1	553100112-00	STEERING WHEEL	1
2	552170016-00	HEX NUT-STEEL GR.8-M16	1
3	552350017-00	WASHER - STEEL-8.4X24X2	1
4	553100111-00	WOODRUFF KEY STEERING WHEEL	1
5	553100109-00	BUSH STEERING SHAFT	2
6	552430023-00	O' RING -20X3	2
7	553100110-00	SHAFT STEERING WHEEL	1
8	558100039-00	STEERING BARCKET WELDMENT	1
9	553100114-00	UNIVERSAL JOINT	1
10	552020022-00	HEX HEAD SCREW-STEEL8.8-M8X25	6
11	552350016-00	WASHER STEEL-9X17X1.6	4
12	553100105-00	CONNECTING SHAFT DRIVE MOTOR	1
13	553100104-00	PARALLEL KEY DRIVE MOTOR	1
14	553100400-00	STEERING SHAFT HOLDER	1
15	552020005-00	HEX HEAD SCREW STEEL - M5X16	2
16	552350008-00	WASHER STEEL - 5.3X10X1	2
17	558100199-00	STEERING SHAFT HOLDER WELDMENT	1
18	553100241-00	SPACER BRUSH LOCK ASSY	1

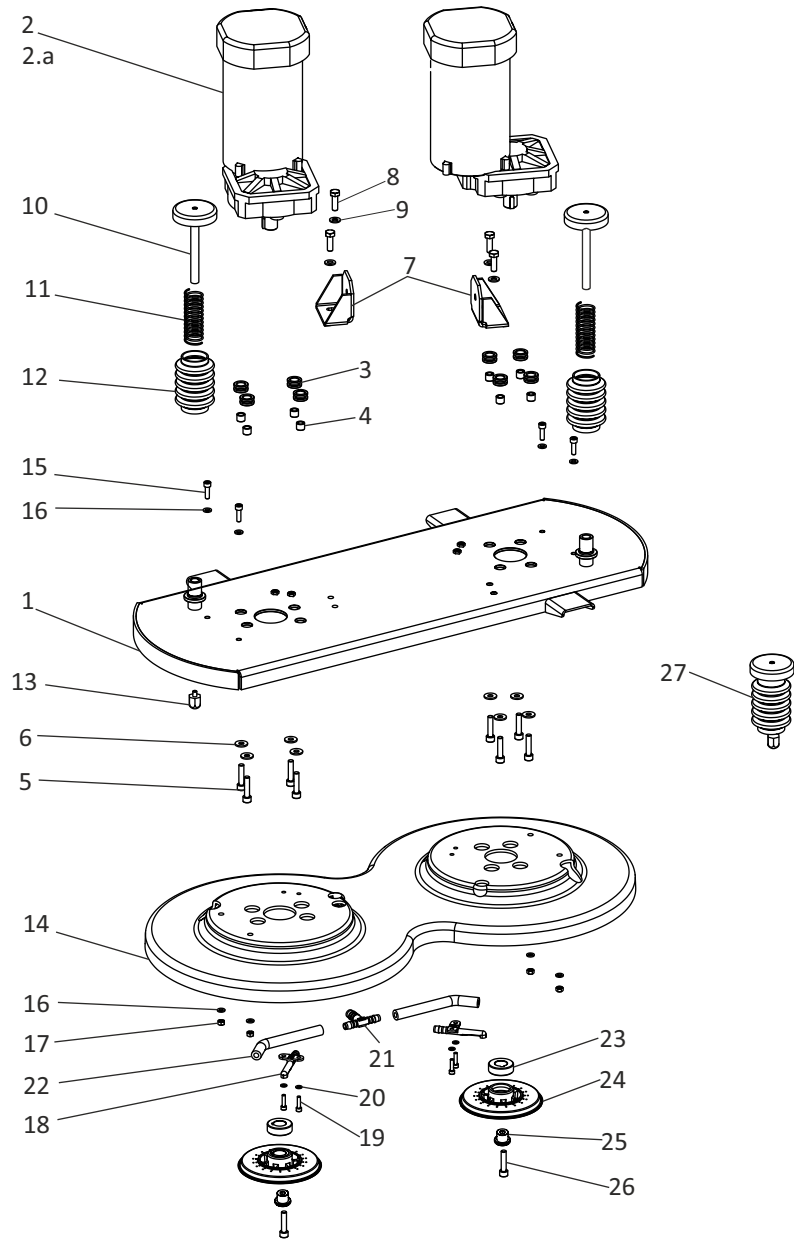

REF. NO	PART NO	DESCRIPTION	QTY
1	558100074-00	BASE PLATE BH WELDMENT	1
2	558100225-00	GEARED MOTOR WITH CONNECTOR ASSY	2
2.a	552670123-00	CARBON BRUSH SET BRUSH MOTOR	4 nos
3	553100238-00	MOUNTING BUSH BM	8
4	553100239-00	SLEEVE BRUSH MOTOR MOUNTING	8
5	552020017-00	HEX HEAD SCREW STEEL - M8X25	8
6	552360014-00	WASHER SS304 - 82X20X2	8
7	553100242-00	L BRACKET BRUSH HEAD LIFTING	2
8	552040009-00	HEX HEAD SCREW-STEEL8.8 - M8X25	4
9	552360013-00	WASHER SS304 - 8.4X16X1.6	4
10	558100075-00	PLUNGER SHAFT WELDMENT	2
11	553100234-00	SPRING BRUSH RELEASE	2
12	553100236-00	BELLOW BRUSH RELEASE	2
13	553100235-00	PLUNGER HEAD BRUSH RELEASE	2
14	553100237-00	BRUSH GUARD	1
15	552240014-00	HEX SOC HEAD CAP SCREW-SS304 - M6X20	4
16	552360011-00	WASHER SS304 - 6.4X12X1.6	8
17	552180005-00	HEX NUT - SS304 - M6	4
18	553350479-00	NOZZLE E-600	2
19	552240008-00	HEX SOC HEAD CAP SCREW-SS304 - M5X20	4
20	552360009-00	WASHER SS304 - 5.3X10X1	4
21	552500054-00	T-JOINT	1
22	553100306-00	FEED TUBE BH	2
23	553100241-00	SPACER-BRUSH LOCK ASSY	2
24	553100240-00	BRUSH LOCK	2
25	553100572-00	SPACER BRUSH MOTOR	2
26	552040010-00	HEX HEAD SCREW-SS304 - M8X40	2
27	558100164-00	PLUNGER ASSY - BRUSH RELEASE	2

NOTE - Item No. 2.a is not showed in the fig.

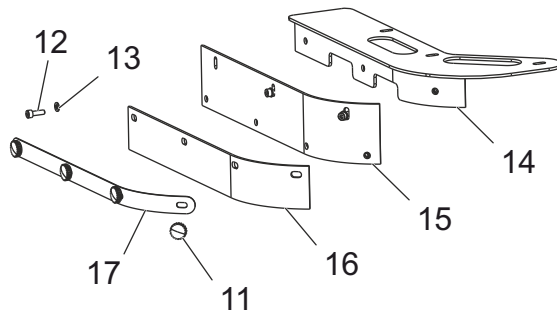
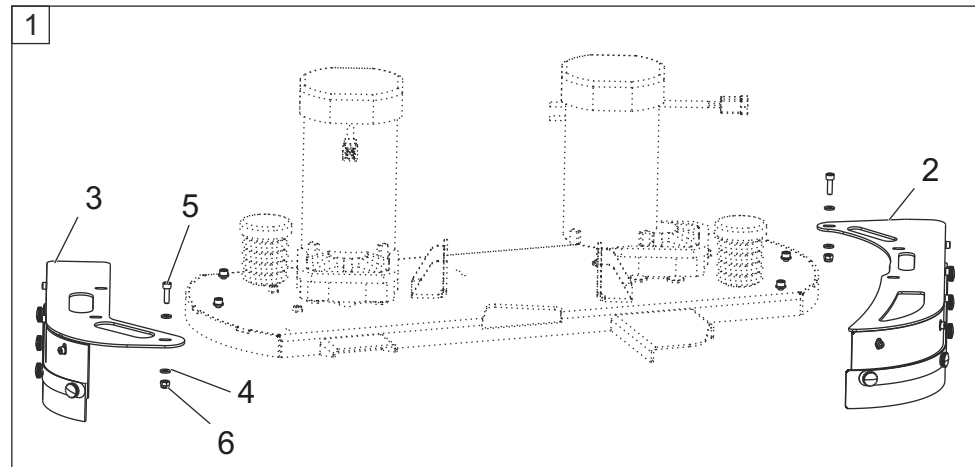
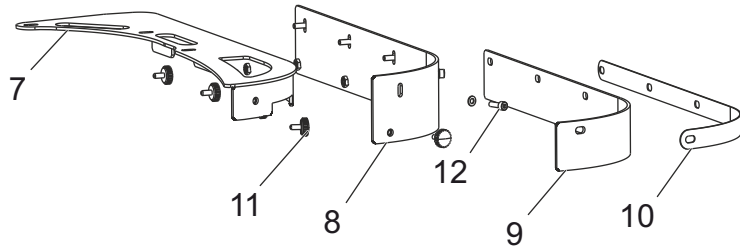

REF. NO	PART NO	DESCRIPTION	QTY
1	558100423-00	SKIRT ASSY KIT RB800	1
2	558100417-00	SKIRT ASSY RH RB800	1
3	558100418-00	SKIRT ASSY LH RB800	1
4	552350011-00	WASHER-STEEL-6.4X12.5X1.6	12
5	552240014-00	HEX SOC HEAD CAP SCREW-SS304-M6X20	6
6	552540003-00	HEX NYLOCK NUT SS304 - M6	6
7	558100421-00	SKIRT HOLDING PLATE WELDMENT RH RB800	1
8	558100422-00	LIP HOLDER PLATE WELDMENT RH RB800	1
9	553100811-00	SKIRT LIP RH RB800	1
10	553100812-00	LIP SUPPORT RH RB800	1
11	553310146-00	KNOB - SQG	9
12	552240007-00	HEX SOC HEAD CAP SCREW-SS304-M5X16	8
13	552350008-00	WASHER-STEEL-5.3X10X1	8
14	558100419-00	SKIRT HOLDING PLATE WELDMENT LH RB800	1
15	558100420-00	LIP HOLDER PLATE WELDMENT LH RB800	1
16	553100813-00	SKIRT LIP LH - RB800	1
17	553100814-00	LIP SUPPORT LH RB800	1

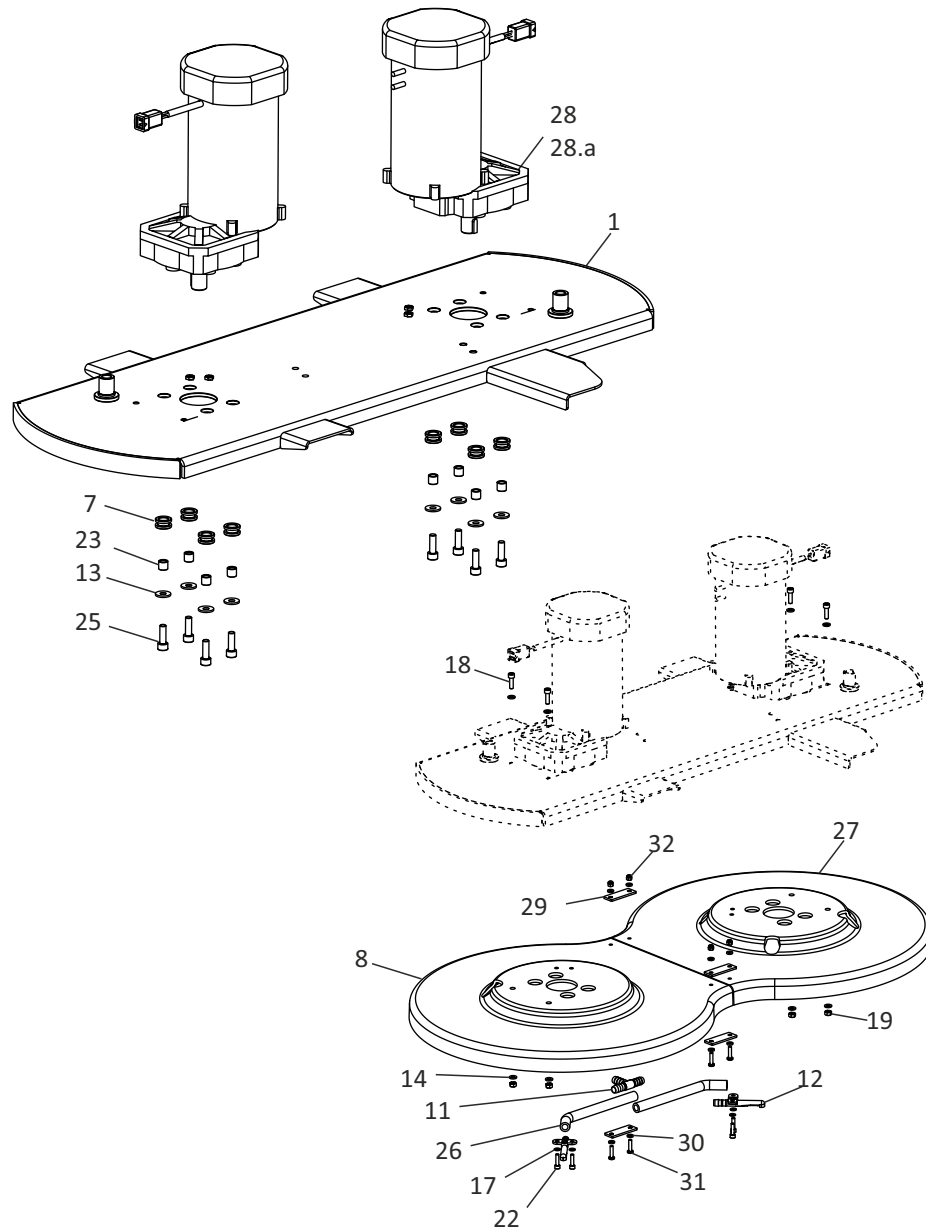

REF. NO	PART NO	DESCRIPTION	QTY
1	558100191-00	BASE PLATE BH WELDMENT - 950	1
2	558100164-00	PLUNGER ASSY BRUSH RELEASE	2
3	558100075-00	PLUNGER SHAFT WELDMENT	1
4	553100234-00	SPRING BRUSH RELEASE	1
5	553100235-00	PLUNGER HEAD BRUSH RELEASE	1
6	553100236-00	BELLOW BRUSH RELEASE	1
7	553100238-00	MOUNTING BUSH BM	8
8	553100369-00	BRUSH GUARD LH	1
9	553100240-00	BRUSH LOCK ASSY	2
10	553100242-00	L BRACKET BRUSH HEAD LIFTING	2
11	552500054-00	T - JOINT	1
12	553350479-00	NOZZLE E-600	2
13	552360014-00	WASHER SS304-8.2X20X2	8
14	552360011-00	WASHER SS304-6.4X12X1.6	8
15	553100572-00	SPACER BRUSH MOTOR	2
16	552360013-00	WASHER SS304-8.4X16X1.6	4
17	552360009-00	WASHER SS304-5.3X10X1	4
18	552240014-00	HEX SOC HD CAP SCREW SS304-M6X20	4
19	552180005-00	HEX NUT SS304-M6	4
20	552040009-00	HEX HEAD SCREW SS304-M8X25	4
21	553100241-00	SPACER - BRUSH LOCK ASSY	2
22	552240008-00	HEX SOC HD CAP SCREW SS304-M5X20	4
23	553100239-00	SLEEVE BRUSH MOTOR MOUNTING	8
24	552040010-00	HEX HEAD SCREW SS304-M8X40	2
25	552230022-00	HEX SOC HD CAP SCREW STEEL-M8X25	8

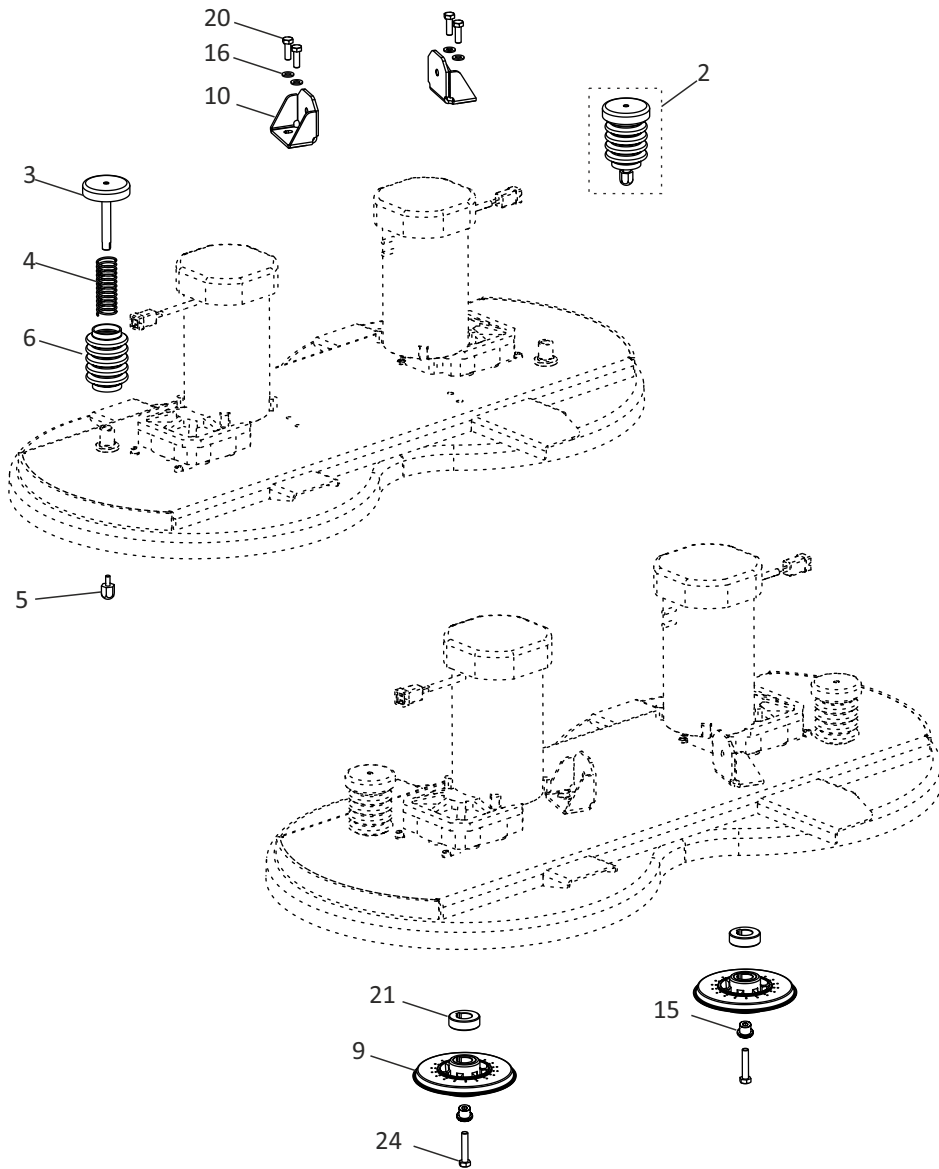

REF. NO	PART NO	DESCRIPTION	QTY
26	553100370-00	FEED TUBE BH 950	2
27	553100368-00	BRUSH GUARD RH	1
28	558100225-00	GEARED MOTOR WITH CONNECTOR ASSY	2
28.a	552670123-00	CARBON BRUSH SET BRUSH MOTOR	4 nos
29	553100411-00	BRUSH GUARD STRIP	4
30	552350008-00	WASHER STEEL-5.3X10X1	8
31	552130013-00	CR PAN HEAD SCREW STEEL-M5X20	4
32	552480005-00	HEX NYLOCK NUT STEEL-M5	4

NOTE - Item No. 28.a is not showed in the fig.

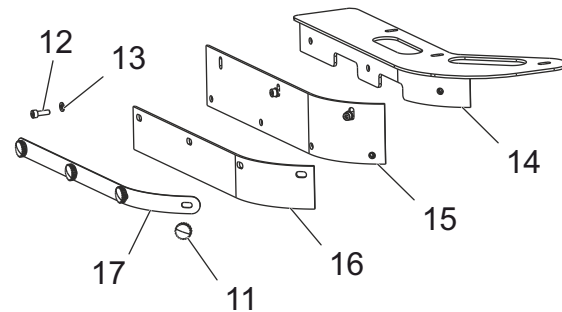
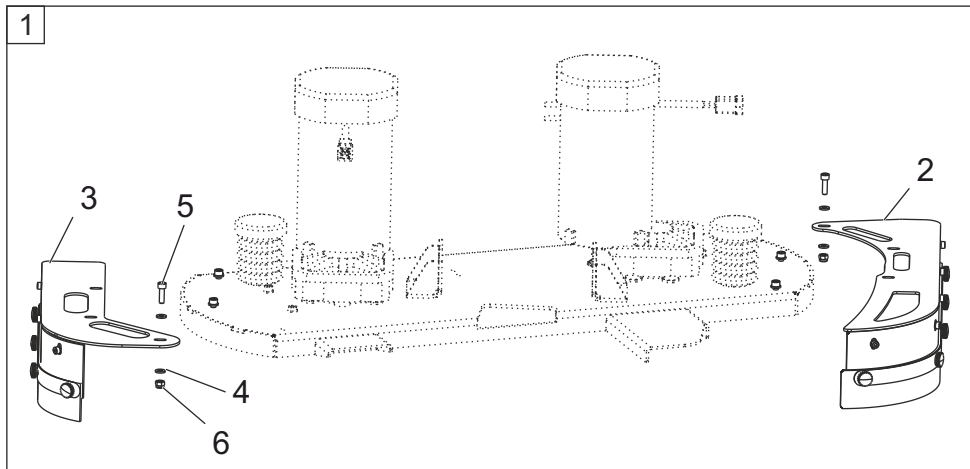
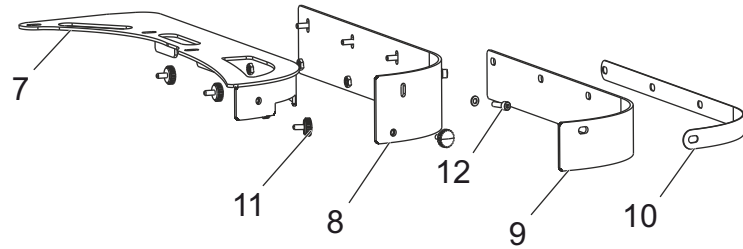

REF. NO	PART NO	DESCRIPTION	QTY
1	558100537-00	SKIRT ASSY KIT RB950	1
2	558100533-00	SKIRT ASSY RH RB950	1
3	558100536-00	SKIRT ASSY LH RB950	1
4	552350011-00	WASHER-STEEL-6.4X12.5X1.6	12
5	552230012-00	HEX SOC HEAD CAP SCREW-SS304-M6X20	6
6	552480006-00	HEX NYLOCK NUT-STEEL GR.6-M6	6
7	558100531-00	SKIRT HOLDING PLATE WELDMNT RH RB950	1
8	558100532-00	LIP HOLDER PLATE WELDMNT RH RB950	1
9	553101005-00	SKIRT LIP RH RB950	1
10	553101004-00	LIP SUPPORT PLATE RH RB950	1
11	553310146-00	KNOB - SQG	9
12	552230004-00	HEX SOC HEAD CAP SCREW -STEEL - M5X12	9
13	552350008-00	WASHER-STEEL-5.3X10X1	9
14	558100534-00	SKIRT HOLDING PLATE WELDMNT LH RB950	1
15	558100535-00	LIP HOLDER PLATE LH WELDMNT RB950	1
16	553101010-00	SKIRT LIP LH RB950	1
17	553101009-00	LIP SUPPORT PLATE LH RB950	1

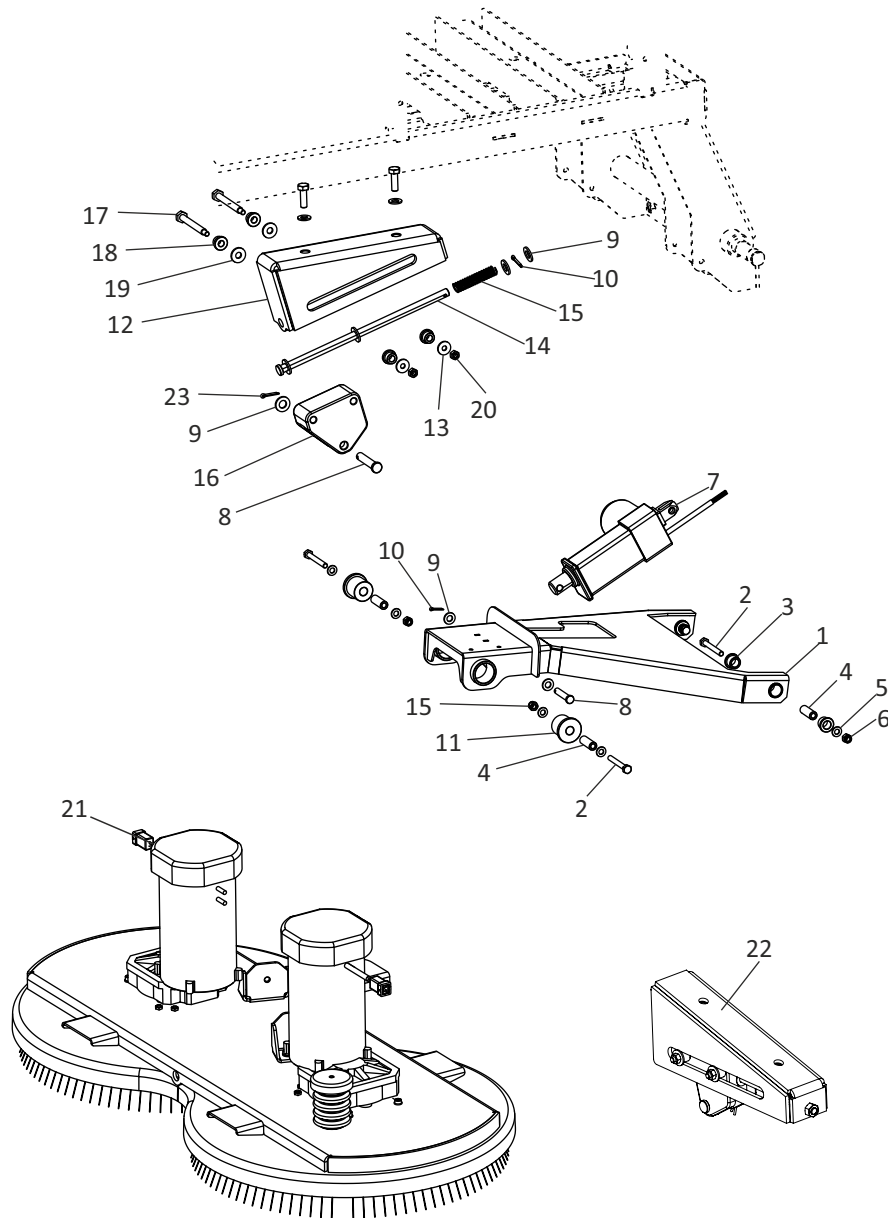

REF. NO	PART NO	DESCRIPTION	QTY
1	558100072-00	BRUSH HEAD LIFTING ARM WELDMENT	1
2	552020020-00	HEX HEAD SCREW-STEEL8.8-M8x65	4
3	553100227-00	BOOT LIFTING ARM MOUNTING	4
4	553100226-00	SLEEVE BM	4
5	552350016-00	WASHER - STEEL-9X17X1.6	8
6	552480008-00	HEX NYLOCK NUT-STEELGR.6-M8	4
7	558100138-00	BRUSH HEAD ACTUATOR WITH CONNECTOR	1
8	553100249-00	MOUNTING PIN ACTUATOR	2
9	552350018-00	WASHER STEEL-10.5X20X2	7
10	553320110-00	LINCH PIN	1
11	553100225-00	BOOT BH MOUNTING	2
12	558100269-00	BRACKET ASSY - ACTUATOR WMT	1
13	552360022-00	WASHER STEEL-6.4X18X1.6	2
14	553100558-00	GUIDE PIN SLIDER ACTUATOR	1
15	553100246-00	SPRING EXTRA PRESSURE	1
16	553100557-00	SLIDER ACTUATOR	1
17	553100248-00	MOUNTING PIN SLIDER ACTUATOR	2
18	553100244-00	BUSH ACTUATOR	4
19	552360005-00	WASHER SS304-8.2X20X2	2
20	552170009-00	HEX NUT-STEEL GR.8-M6	2
21 (RB800)	558100098-00	BRUSH HEAD GROUP - 800	1
21 (RB950)	558100190-00	BRUSH HEAD GROUP - 950	1
22	558100286-00	MOUNTING BRACKET ACTUATOR GROUP	1
23	552330012-00	COTTER PIN STEEL - 3X25	1

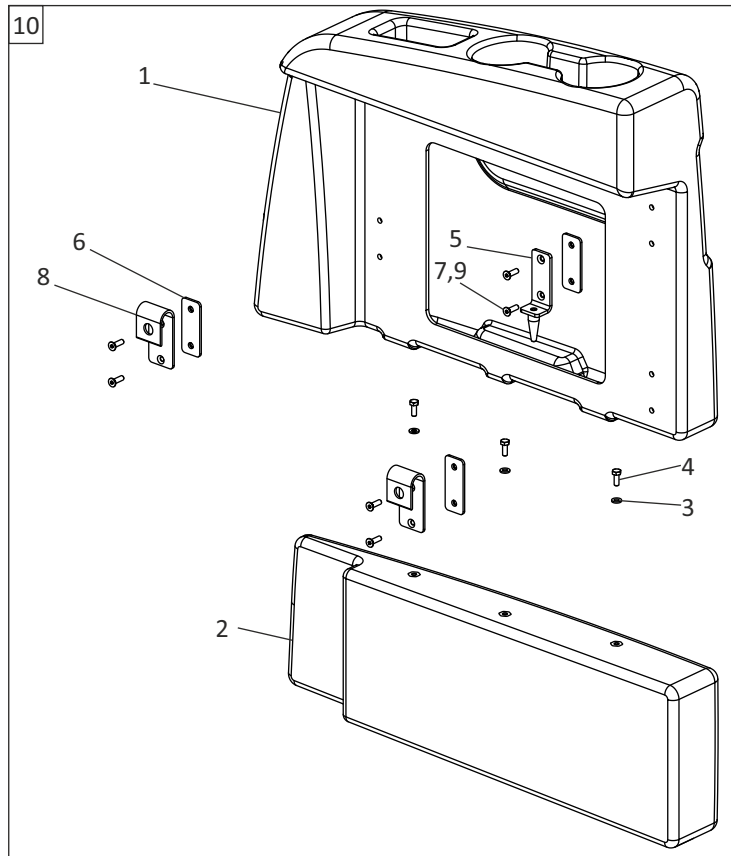

REF. NO	PART NO	DESCRIPTION	QTY
1	553100005-00	SIDE DOOR RH	1
2	553100007-00	SIDE DOOR BOTTOM RH	1
3	552350011-00	WASHER STEEL - 6.4X12.5X1.6	3
4	552020008-00	HEX HEAD SCREW STEEL - M6X20	3
5	558100059-00	GUIDE PIN SIDE DOOR WELDMENT	1
6	558100062-00	PLATE GUIDE PIN MOUNT WELDMENT	3
7	552220009-00	HEX SOC CSK HD SCREW SS304 - M6X20	6
8	558100416-00	HOOK MALE SIDE DOOR	2
9	553100403-00	WASHER - 6.4X16X5	2
10	558100063-00	ASSY SIDE DOOR RH	1

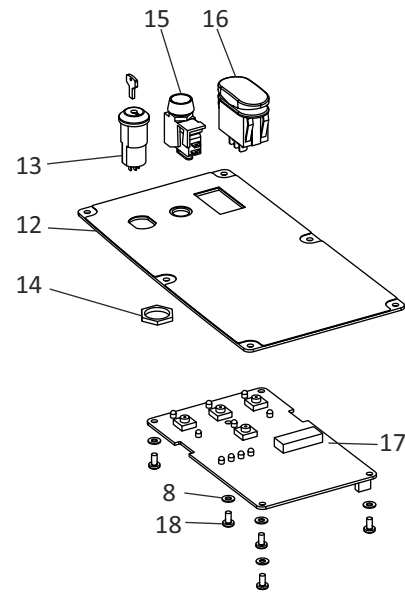
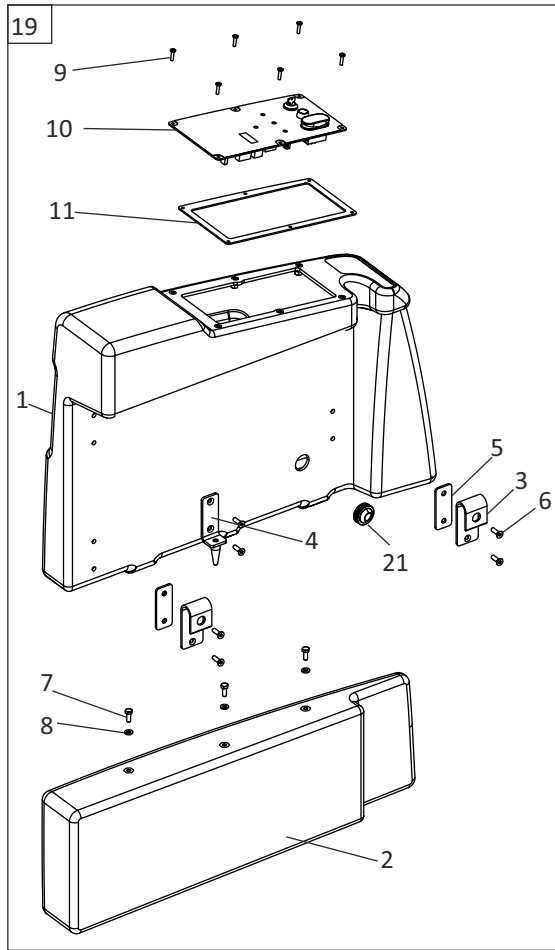

REF. NO	PART NO	DESCRIPTION	QTY
1	553100004-00	SIDE DOOR LH	1
2	553100006-00	SIDE DOOR BOTTOM LH	1
3	558100416-00	HOOK MALE SIDE DOOR	2
4	558100059-00	GUIDE PIN SIDE DOOR WELDMENT	1
5	558100062-00	PLATE GUIDE PIN MOUNT WELDMENT	3
6	552220009-00	HEX SOC CSK HD SCREW SS304-M6X20	6
7	552020008-00	HEX HEAD SCREW-STEEL8.8-M6X20	3
8	552350011-00	WASHER - STEEL-6.4X12.5X1.6	8
9	552140010-00	CR PAN HEAD SCREW-STEEL-M4X16	6
10 (RB800)	558100060-00	PANEL BOARD ASSY	1
10 (RB950)	558100208-00	PANEL BOARD ASSY	1
11	553100176-00	GASKET PANEL BOARD	1
12	558100061-00	PANEL BOARD WELDMENT	1
13	558100146-00	KEY SWITCH WITH CONNECTOR	1
14	553320466-00	NUT KEY SWITCH	1
15	553100172-00	HORN SWITCH	1
16	553100171-00	SWITCH FNR	1
17	558100084-00	A1 CONTROL BOARD ASSY	1
18	552140006-00	CR PAN HEAD SCREW-SS304-M4X8	5
19 (RB800)	558100058-00	ASSY SIDE DOOR LH	1
19 (RB950)	558100209-00	ASSY SIDE DOOR LH	1
20 (RB800)	557100002-00	PANEL STICKER	1
20 (RB950)	557100033-00	PANEL STICKER	1
21	553100578-00	GROMMET SIDE DOOR LH	1

NOTE - Item No. 20 is not showed in the fig.

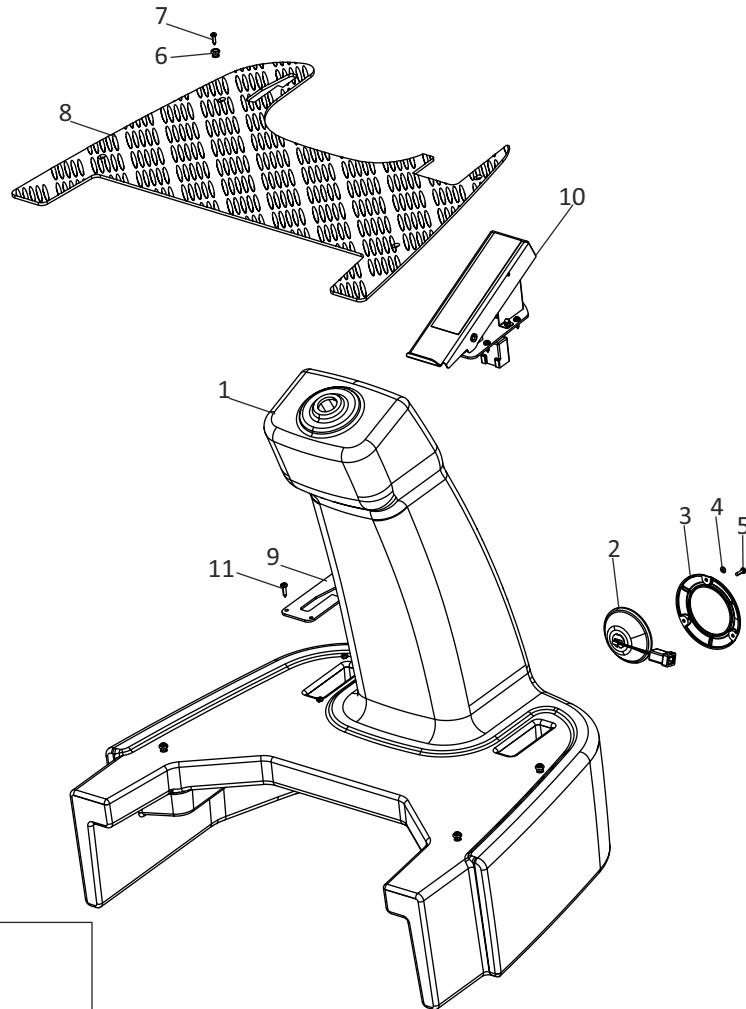

REF. NO	PART NO	DESCRIPTION	QTY
1	553100003-00	COVER STEERING	1
2	558100065-00	ASSY WORKING LAMP	1
3	553100182-00	CLAMP WORKING LAMP	1
4	552350005-00	WASHER STEEL - 4.3X9X0.8	6
5	552130006-00	CR PAN HEAD SCREW STEEL - M4X15	3
6	553100183-00	LOCK FLOOR MAT	3
7	552280007-00	CRPH STS SS304 - 4.2X16	3
8	553100184-00	FLOOR MAT	1
9	553100619-00	PROFILE PLATE BRAKE PEDAL	1
10	558100259-00	ACCELERATOR GROUP WITH CONNECTOR	1
11	552290006-00	CEPH SELF TAPPING SCREW STEEL - 4.8X20	4
12	558100257-00	BASE ASSY WELDMENT	1
13	558100258-00	TOP PLATE WELDMENT	1
14	553100126-00	LIMIT SWITCH ACCELERATOR	1
15	Refer Electrical Circuit	POTENTIOMETER	1
16	553100488-00	CAM POT	1
17	553100487-00	TOP SPRING GUIDE	1
18	553100486-00	BOTTOM SPRING GUIDE	1
19	553100494-00	GUIDE SPRING 18	1
20	553100502-00	GUIDE SPRING 9.6	1
21	55310495-00	TOP GUIDE PIN	1
22	553100491-00	GUIDE BUSH	2
23	553100498-00	STEPPED PIN	1
24	553100496-00	GUIDE SLEEVE	1
25	553100499-00	COVER ACCELERATOR	1
26	552670026-00	EXTERNAL CIRCLIP TYPE E - DIA 4	1
27	552100011-00	CR CSK HEAD SCREW STEEL - M5X12	1
28	552350008-00	WASHER STEEL - 5.3X10X1	5

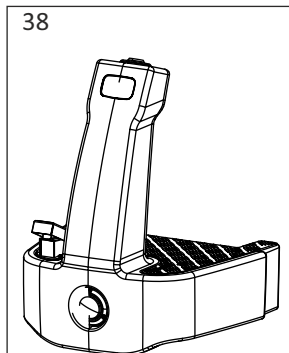

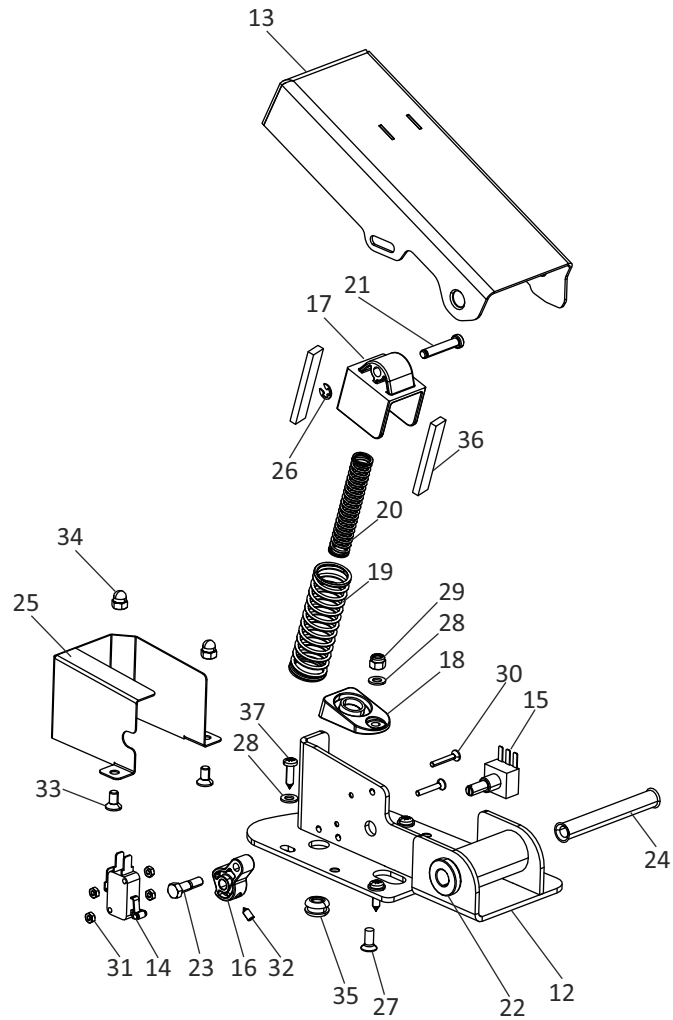

REF. NO	PART NO	DESCRIPTION	QTY
29	552480005-00	HEX NYLOCK NUT - M5	1
30	552210030-00	HEX SOC CSK HD SCREW STEEL - M3X20	2
31	552180002-00	HEX NUT SS304 - M3	4
32	552690004-00	GRUB SCREW - M4X8	1
33	552220003-00	HEX SOC CSK HD SCREW SS304 - M5X10	2
34	552300001-00	DOMECAP NUT SS304 - M5	2
35	553250100-00	GROMMET	1
36	553100500-00	EPDM GASKET - 50X10X4	2
37	552280007-00	CRPH STS SS304 - 4.2X16	4
38	558100064-00	ASSY COVER STEERING GROUP	1

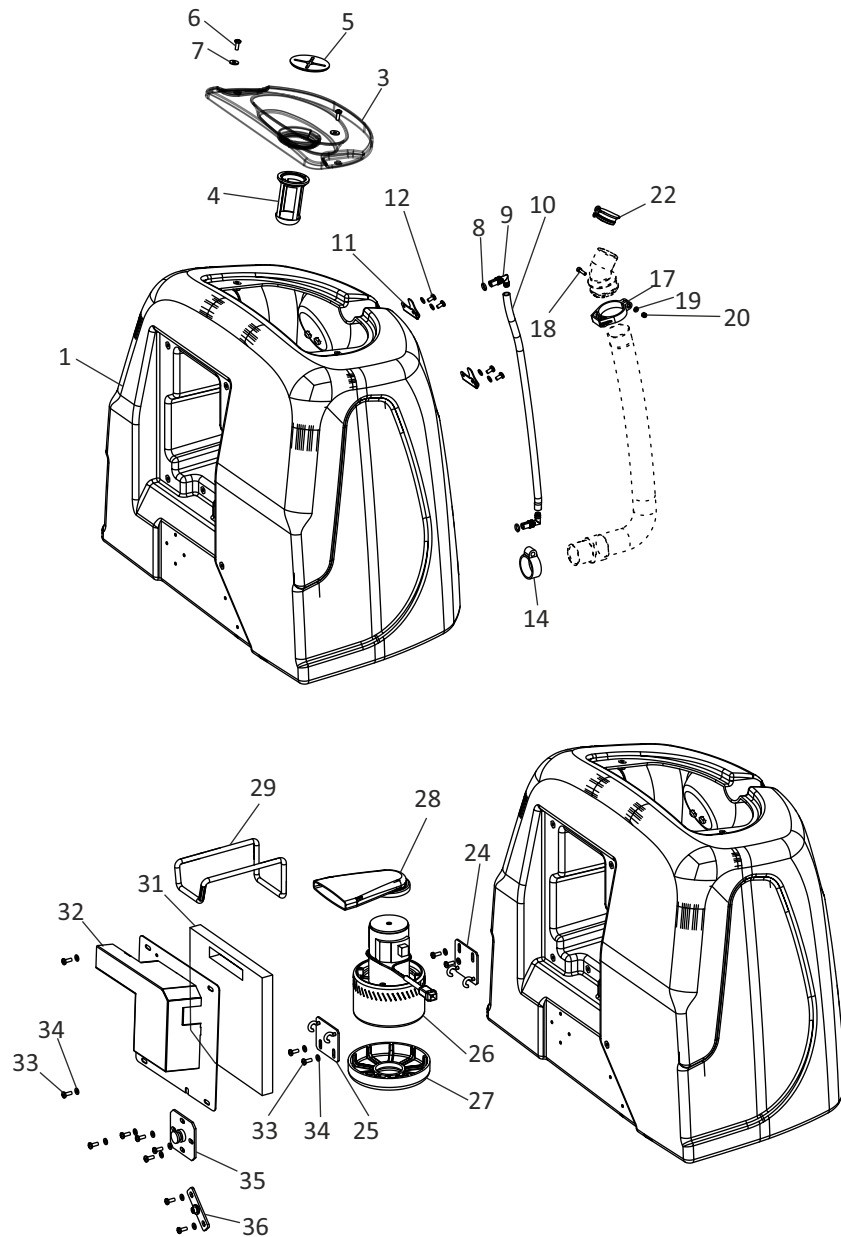

REF. NO	PART NO	DESCRIPTION	QTY
1	553100002-00	FRESH TANK ASSY	1
2	558100026-00	LID ASSY	1
3	553100066-00	LID FRESH TANK	1
4	553230085-00	GUIDE FLOAT	1
5	553100068-00	LIP SEAL	1
6	552130018-00	CR PAN HEAD SCREW-STEEL-M6X16	2
7	552350013-00	WASHER - STEEL-6.4X18X3.0	2
8	553100045-00	GASKET ELBOW CONNECTOR	2
9	553100044-00	ELBOW CONNECTOR FT	2
10	553100305-00	INDICATOR HOSE FT	1
11	553350086-00	HOOK DRAIN HOSE	2
12	552130017-00	CR PAN HEAD SCREW-STEEL-M6X12	4
13	553100328-00	FEED TUBE	1
14	552670022-00	HOSE CLAMP - 40-60	1
15	553100041-00	CONNECTOR FRESH TANK	1
16	553100040-00	GASKET CONNECTOR FT	1
17	553320588-00	CLAMP DRAIN HOSE	1
18	552230006-00	HEX SOC HEAD CAP SCREW-STEEL-M5X20	1
19	552360010-00	WASHER SS304-5.2X10X1.6	1
20	552480005-00	HEX NYLOCK NUT-STEELGR.6-M5	1
21	553100054-00	FLOAT BLOCK	1
22	558320053-00	CAP WITH CHAIN ASSY	1
23.a	558100109-00	DRAIN HOSE ASSY FT	1
23.b	558100254-00	DRAIN HOSE ASSY FT - OIL RESISTANT	1

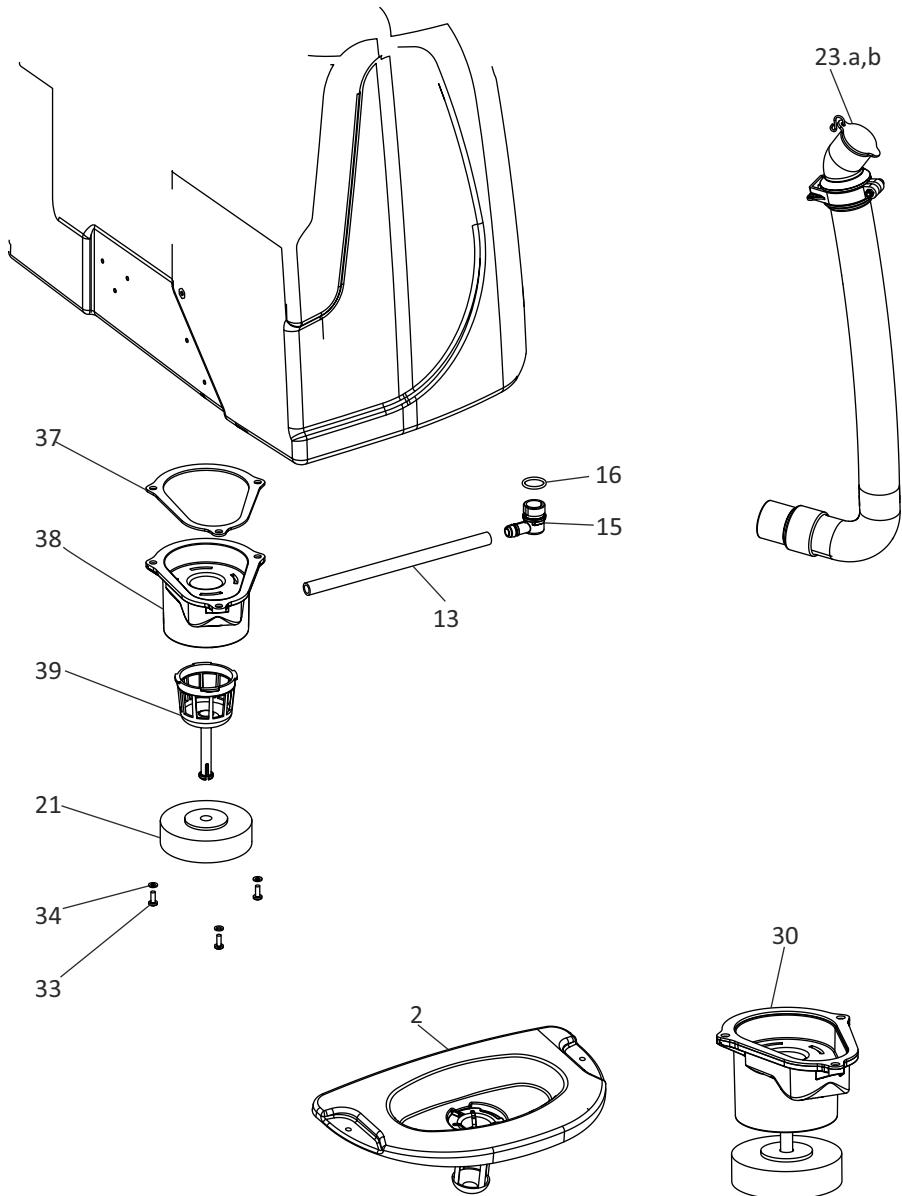

REF. NO	PART NO	DESCRIPTION	QTY
24	558100020-00	VM HOLDER INNER WELDMENT	1
25	558100021-00	VM HOLDER OUTER WELDMENT	1
26	558100110-00	VACUUM MOTOR 3 STAGE WITH CONNECTOR ASSY	1
26.a	553100346-00	CARBON BRUSH SET VACUUM MOTOR	2
27	553100057-00	HUB VACUUM MOTOR	1
28	553100059-00	AIR INLET CHAMBER VM	1
29	553100277-00	O-RING VACUUM MOTOR	1
30	558100019-00	FLOAT ASSY	1
31	558100214-00	V.M MOTOR COVER GROUP	1
32	558100024-00	COVER VM WELDMENT	1
33	552130018-00	CR PAN HEAD SCREW-STEEL-M6X16	13
34	552350013-00	WASHER STEEL-6.4X18X2	13
35	558100090-00	TANK LOCK WELDMENT	1
36	558100017-00	HOLDER ASSY FT	1
37	553100276-00	GASKET BODY FLOAT	1
38	553100051-00	BODY FLOAT	1
39	553100053-00	GUIDE FLOAT	1

NOTE - Item No. 26.a is not showed in the fig.

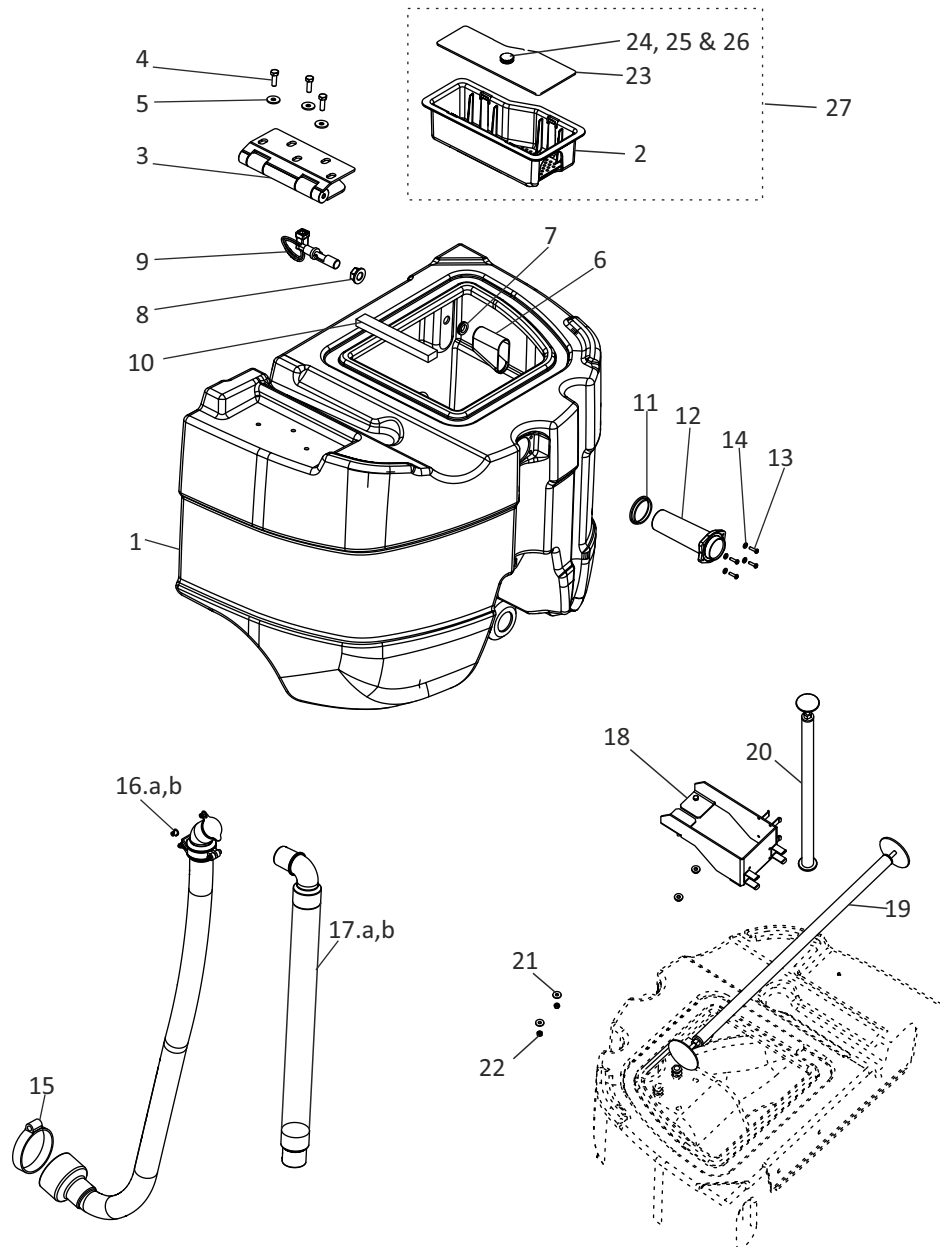

REF. NO	PART NO	DESCRIPTION	QTY
1	553100001-00	COLLECTION TANK ASSY	1
2	553100186-00	COLLECTION TRAY	1
3	558100011-00	TANK HINGE ASSY	1
4	552040009-00	HEX HEAD SCREW-SS304-M8X25	5
5	552360015-00	WASHER SS304-8.2X24X2.2	3
6	558100003-00	FLOAT CAP ASSY	1
7	553320465-00	GASKET FLOAT SWITCH	1
8	553100013-00	LOCK NUT FLOAT SWITCH	1
9	558100141-00	FLOAT SWITCH WITH CONNECTOR ASSY	1
10	553100278-00	TANK GASKET	1
11	553100014-00	SEAL CONNECTOR SQUEEGEE	1
12	553100280-00	SUCTION PIPE CT	1
13	552280007-00	CRPH-ST5-SS304-4.2X16	4
14	552360010-00	WASHER SS304-5X10X1.6	4
15	552670106-00	HOSE CLAMP - 80-100	1
16.a	558100104-00	DRAIN HOSE ASSY CT	1
16.b	558100253-00	DRAIN HOSE ASSY CT - OIL RESISTANT	1
17.a	558100108-00	SQUEEGEE HOSE ASSY	1
17.b	558100252-00	SQUEEGEE HOSE ASSY - OIL RESISTANT	1
18	558100171-00	BRACKET CT SUPPORT WELDMENT	1
19	558100168-00	PIPE ASSY HOR SUPPORT CT	1
20	558100169-00	PIPE ASSY VERTICAL SUPPORT CT	1
21	552360022-00	WASHER SS304-6.4X18X1.6	2
22	552180005-00	HEX NUT SS304-M6	2
23	553100187-00	LID COLLECTION TRAY	1
24	553310146-00	KNOB	1
25	552360009-00	WASHER SS304 - 5.3X10X1.0	1
26	552180004-00	HEX NUT SS - M5	1
27	558100107-00	COLLECTION TRAY ASSY	1

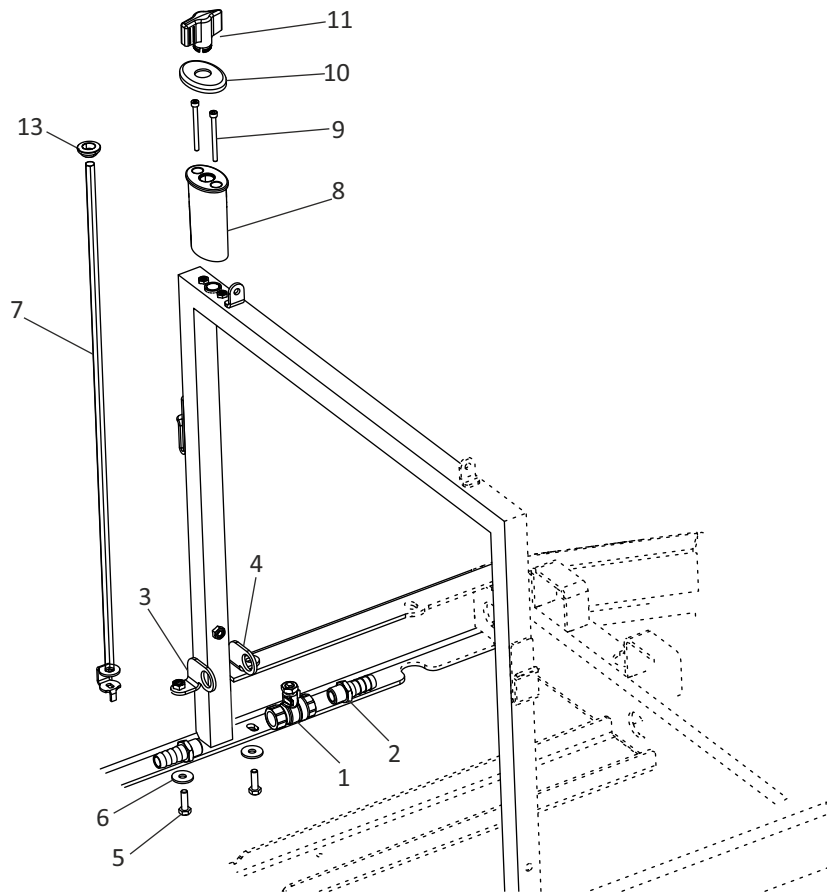

REF. NO	PART NO	DESCRIPTION	QTY
1	553100258-00	BALL VALVE	1
2	552500055-00	HOSE NIPPLE BALL VALVE	2
3	558100081-00	BRACKET BALL VALVE MOUNT LH	1
4	558100082-00	BRACKET BALL VALVE MOUNT RH	1
5	552020007-00	HEX HEAD SCREW-STEEL8.8-M6X16	2
6	552350011-00	WASHER STEEL-6.4X12.5X1.6	2
7	558100083-00	ACTUATOR BALL VALVE WELDMENT	1
8	553100264-00	COVER FLOW INDICATOR	1
9	552210019-00	HEX SOC HEAD CAP SCREW-STEEL-M4X50	2
10	553100180-00	CAP FLOW CONTROL VALVE	1
11	553100265-00	HANDLE VALVE	1
12	557100012-00	STICKER - WATER FLOW CONTROL	1
13	553430190-00	BUSH LEVER	1



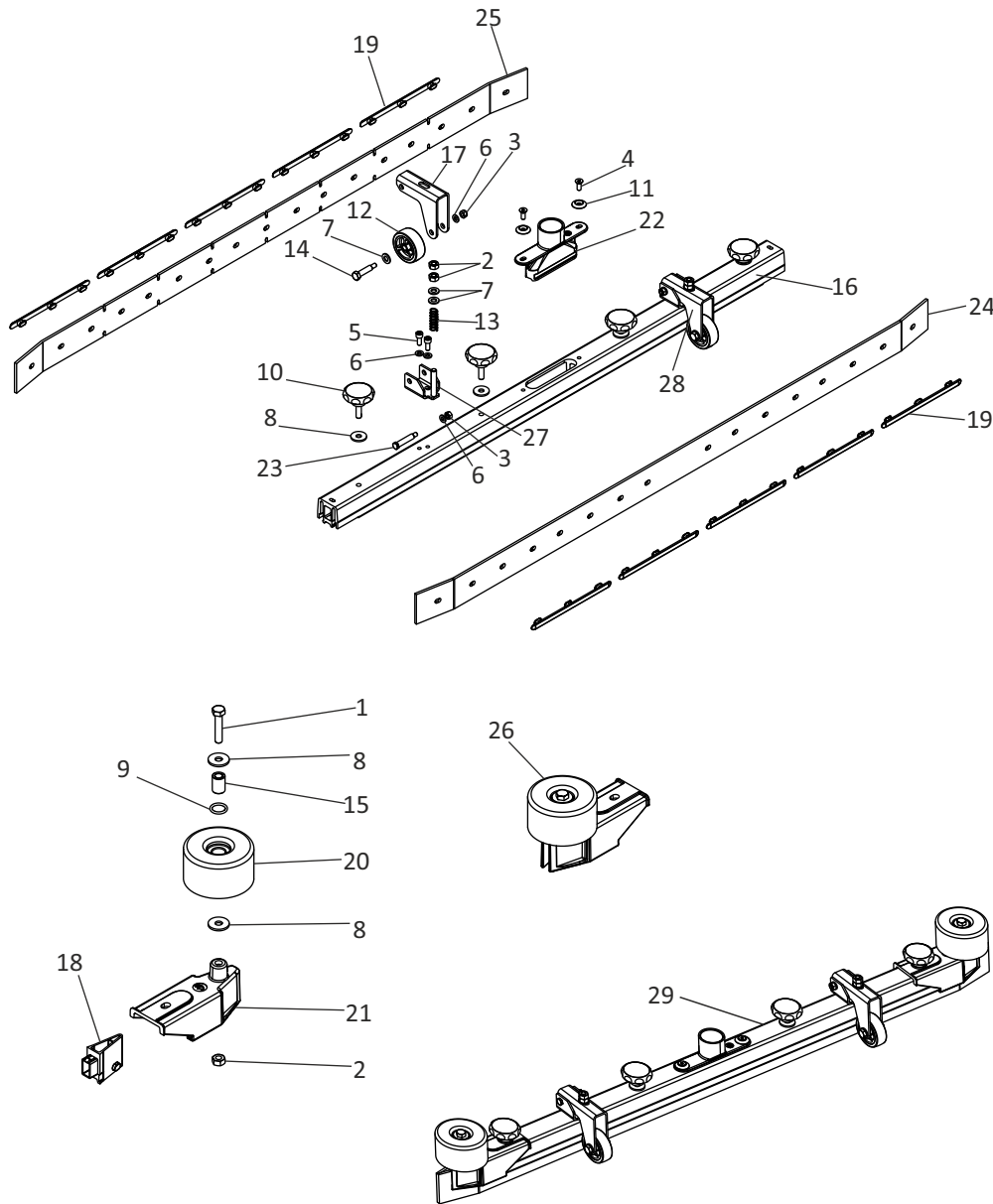

REF. NO	PART NO	DESCRIPTION	QTY
1	552040010-00	HEX-HEAD-SCREW-SS304 - M8X40	2
2	552170012-00	HEX NUT – STEELGR.8 - M8	4
3	552180005-00	HEX NUT-STEEL - M6	2
4	552220008-00	HEX-SOC-CSK-HD-SCREW-SS304 - M6X16	2
5	552240013-00	HEX SOC HEAD CAP SCREW-SS304 - M6X15	4
6	552360011-00	WASHER-SS304 - 6.4X12X1.6	6
7	552360013-00	WASHER-SS305 - 8.4X16X1.6	4
8	552360015-00	WASHER-SS306 - 8.2X24X2.2	4
9	552430014-00	O-RING - 15X2.5	2
10	558350358-00	KNOB ASSY	4
11	553310122-00	WASHER - DEFLECTOR	2
12	558320140-00	WHEEL - SQUEEGEE	2
13	553310207-00	SPRING-PILLER SQG.	2
14	553350448-00	LOCK PIN-CASTOR WHEEL	2
15	553350492-00	SPACER DEFLECTOR - E600	2
16	553100161-00	BODY SQUEEGEE-1100	1
17	553350565-00	BRACKET - SQG WHEEL	2
18	553350566-00	SQUEEGEE END CAP	2
19	553350567-00	STRIP LIP LOCK	10
20	553350568-00	DEFLECTOR ROLLER	2
21	553350569-00	SQUEEGEE LIP GUIDE	2
22	553350570-00	SUCTION PORT	1
23	553350571-00	PIN-SQG CASTOR	2
24	553100162-00	SQUEEGEE LIP OUTER 1100	1
25	553100163-00	SQUEEGEE LIP INNER 1100	1
26	558350352-00	DEFLECTOR ROLLER SQG ASSY	2
27	558350354-00	BRACKET SQG-WELDMENT	2
28	558350355-00	BRACKET SQG ASSY	2
29	558100057-00	SQUEEGEE GROUP - 1100	1

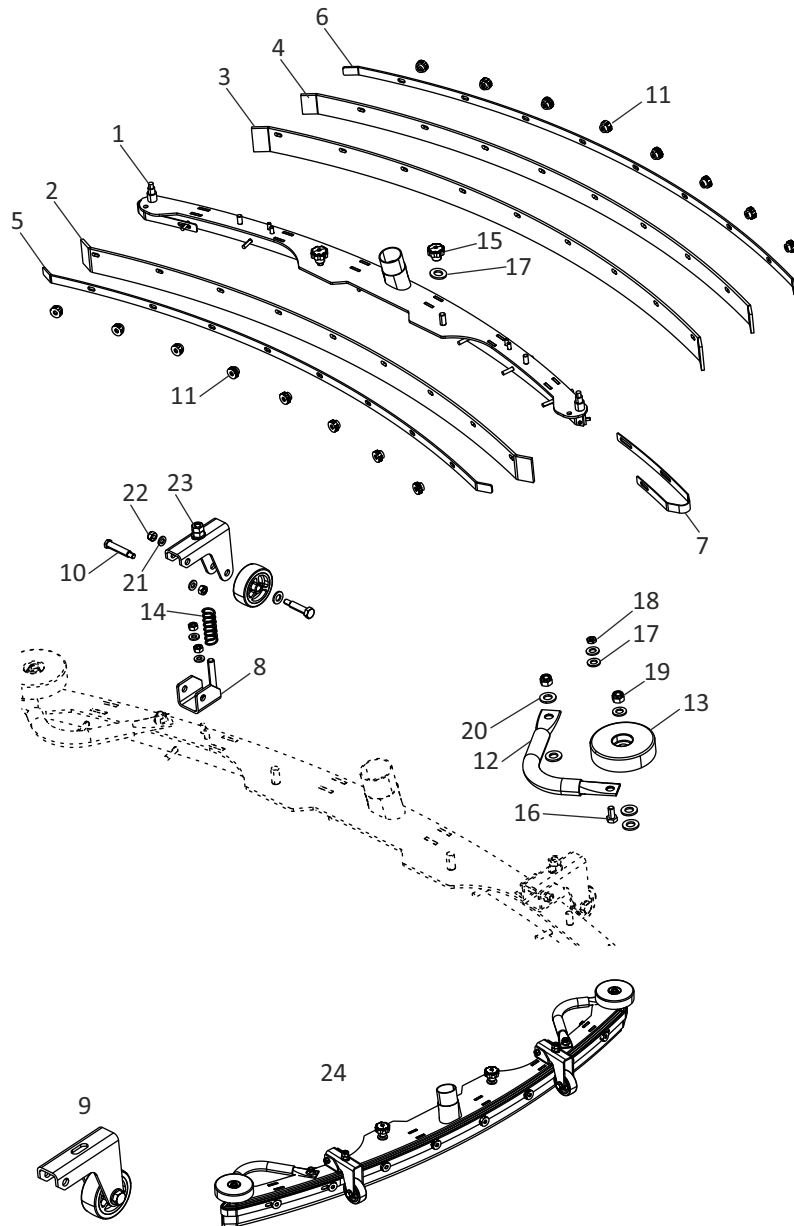

REF. NO	PART NO	DESCRIPTION	QTY
1	558100262-00	BODY SQUEEGEE WELDMENT	1
2	553100504-00	SQUEEGEE LIP INNER	1
3	553100503-00	SQUEEGEE LIP OUTER	1
4	553100576-00	SQUEEGEE LIP SUPPORT OUTER	1
5	553100567-00	LIP SUPPORT PLATE INNER	1
6	553100568-00	LIP SUPPORT PLATE OUTER	1
7	553100349-00	SQUEEGEE END COVER PLATE	2
8	558350354-00	BRACKET SQUEEGEE WELDMENT	2
9	558350355-00	BRACKET SQUEEGEE ASSY	2
10	553350571-00	PIN SQUEEGEE CASTOR	2
11	558320138-00	KNOB LIP	20
12	553320405-00	PIPE PROTECTION	2
13	553320391-00	DEFLECTOR ROLLER SQUEEGEE	2
14	553310207-00	SPRING PILLAR SQUEEGEE	2
15	558320139-00	KNOB HANDLE	2
16	552020015-00	HEX HEAD SCREW STEEL - M8X16	2
17	552350018-00	WASHER STEEL - 10.5X20X2	9
18	552250004-00	HEX LOCK NUT STEEL - M8	2
19	552480008-00	HEX NYLOCK NUT STEEL - M8	4
20	552350016-00	WASHER STEEL - 9.0X17X1.6	5
21	552350011-00	WASHER STEEL - 6.4X12.5X1.6	6
22	552180005-00	HEX NUT SS304 - M6	6
23	552170012-00	HEX NUT STEEL - M8	4
24	558100261-00	SQUEEGEE GROUP PARABOLIC - 1100	1

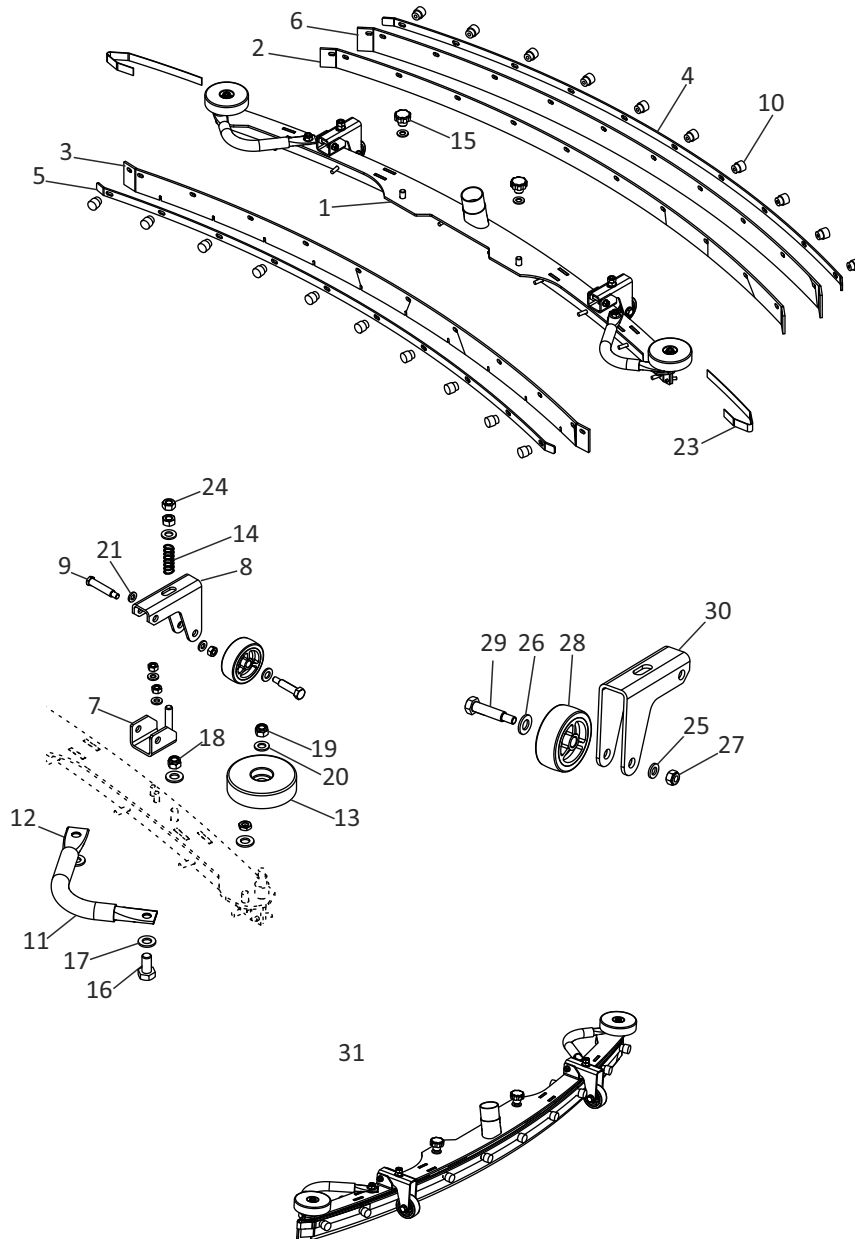

REF. NO	PART NO	DESCRIPTION	QTY
1	558100194-00	SQUEEGEE BODY WELDMENT	1
2	553100379-00	SQUEEGEE LIP INNER - 1200	1
3	553100378-00	SQUEEGEE LIP OUTER - 1200	1
4	553100376-00	LIP SUPPORT PLATE OUTER	1
5	553100377-00	LIP SUPPORT PLATE INNER	1
6	553100414-00	SQUEEGEE LIP SUPPORT - 1200	1
7	553580427-00	BRACKET SQUEEGEE WELDMENT	2
8	553580428-00	BRACKET SQUEEGEE ASSY	2
9	553530716-00	PIN SQUEEGEE CASTOR	2
10	558320138-00	KNOB LIP	20
11	553320404-00	HOSE PIPE PROTECTION	2
12	553320405-00	PIPE PROTECTION	2
13	553320391-00	DEFLECTOR ROLLER SQUEEGEE	2
14	553310207-00	SPRING PILLAR SQUEEGEE	2
15	558320139-00	KNOB HANDLE	2
16	552020015-00	HEX HEAD SCREW STEEL-M8X16	2
17	552350018-00	WASHER STEEL-105X20X2	9
18	552250004-00	HEX LOCK NUT STEEL-M8	2
19	552480008-00	HEX NYLOCK NUT STEEL-M8	4
20	552350016-00	WASHER STEEL-9.0X17X1.6	5
21	552350011-00	WASHER STEEL-6.4X12.5X1.6	6
22	552180005-00	HEX NUT SS304-M6	6
23	553320403-00	END CLAMP	2
24	552170012-00	HEX NUT STEEL-M8	4
25	552360011-00	WASHER SS304-6.4X12X1.6	1
26	552360013-00	WASHER SS304-8.4X16X1.6	1
27	552480006-00	HEX NYLOCK NUT STEEL-M6	1
28	558320140-00	WHEEL - SQUEEGEE	1
29	553350448-00	LOCK PIN - CASTOR WHEEL	1
30	553350565-00	BRACKET - SQG WHEEL	1
31	558100195-00	SQUEEGEE GROUP PARABOLIC	1

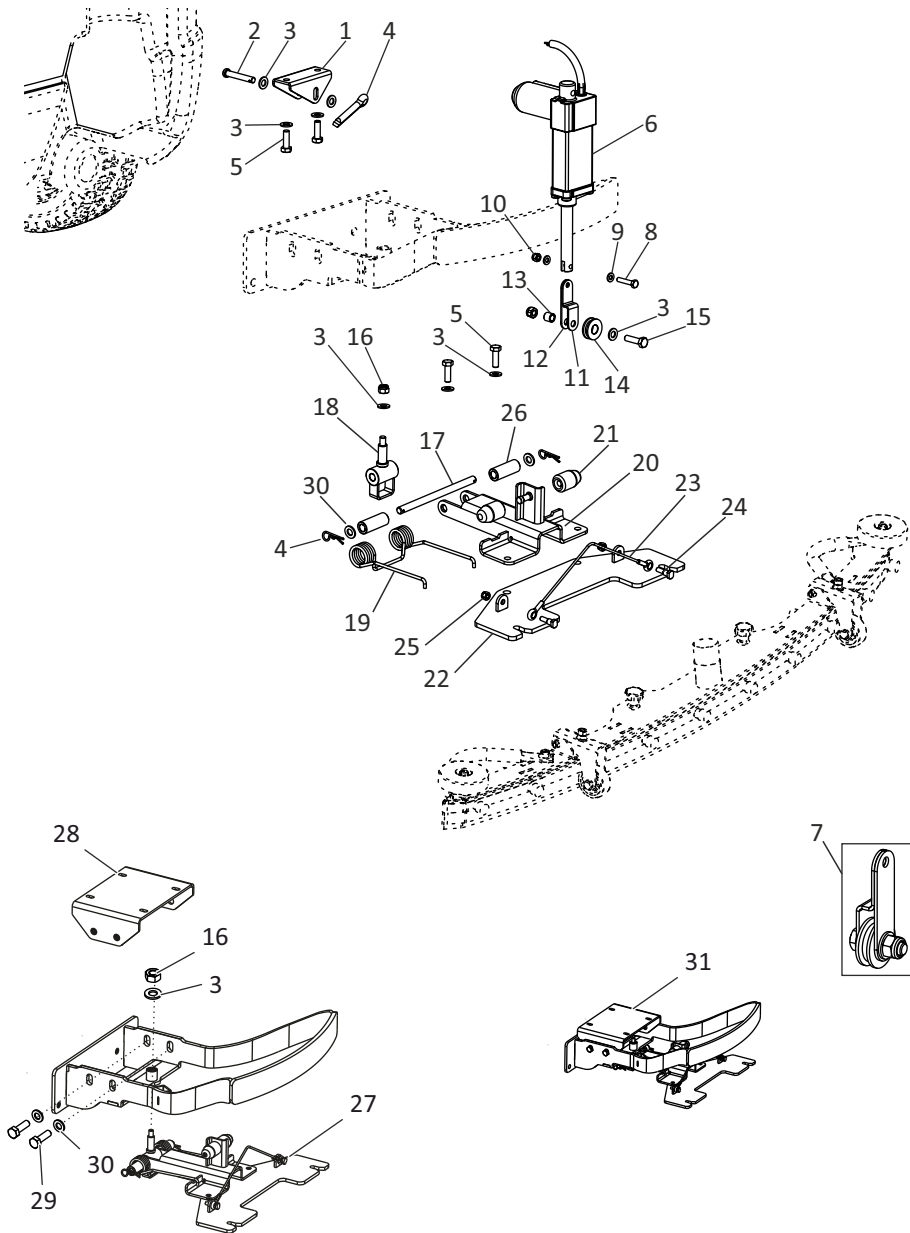

REF. NO	PART NO	DESCRIPTION	QTY
1	553100021-00	BRACKET SQG ACTUATOR MTG	1
2	553100028-00	PIN ACTUATOR MOUNT	1
3	552350016-00	WASHER STEEL-9X17X1.6	9
4	552330012-00	COTTER PIN - 3X25	2
5	552020017-00	HEX HEAD SCREW - STEEL 8.8 - M8X25	4
6	558100142-00	SQUEEGEE ACTUATOR WITH CONNECTOR	1
7	558100106-00	ROLLER ASSY SQUEEGEE	1
8	552020010-00	HEX HEAD SCREW-STEEL8.8-M6X30	1
9	552350011-00	WASHER STEEL-6.4X12.5X1.6	2
10	552480006-00	HEX NYLOCK NUT-STEELGR.6-M6	1
11	553100024-00	ROLLER MTG BRACKET SQG	1
12	553100025-00	ROLLER MTG PLATE SQG	1
13	553100026-00	SLEEVE ROLLER	1
14	553100027-00	ROLLER SQG	1
15	552040029-00	HEX HEAD SCREW-SS304-M8X30	1
16	552480008-00	HEX NYLOCK NUT-STEEL-M8	3
17	553320411-00	STUD	1
18	558100053-00	ASSY SQG HOLDER	1
19	553100390-00	SPRING SQUEEGEE RB 800	1
20	558100054-00	BRACKET SQG LIFT WELDMENT	1
21	553100273-00	BOOT SQUEEGEE STOPPER	2
22	558100055-00	BRACKET SQG MOUNT WELDMENT	1
23	558100056-00	ASSY ROPE SQUEEGEE	1
24	553100143-00	PIN SEAT HINGE	2
25	552480006-00	HEX NYLOCK NUT-STEELGR.6-M6	2
26	553100805-00	BUSH SLEEVE	2
27	558100052-00	SQUEEGEE LIFTING ASSY	1
28	558100319-00	SUPPORT TANK WELDMENT	1
29	552020023-00	HEX HEAD SCREW STEEL - M10X30	4
30	552350018-00	WASHER STEEL - 10.5X20X2	6
31	558100320-00	SQUEEGEE LIFTING GROUP COMPLETE	1

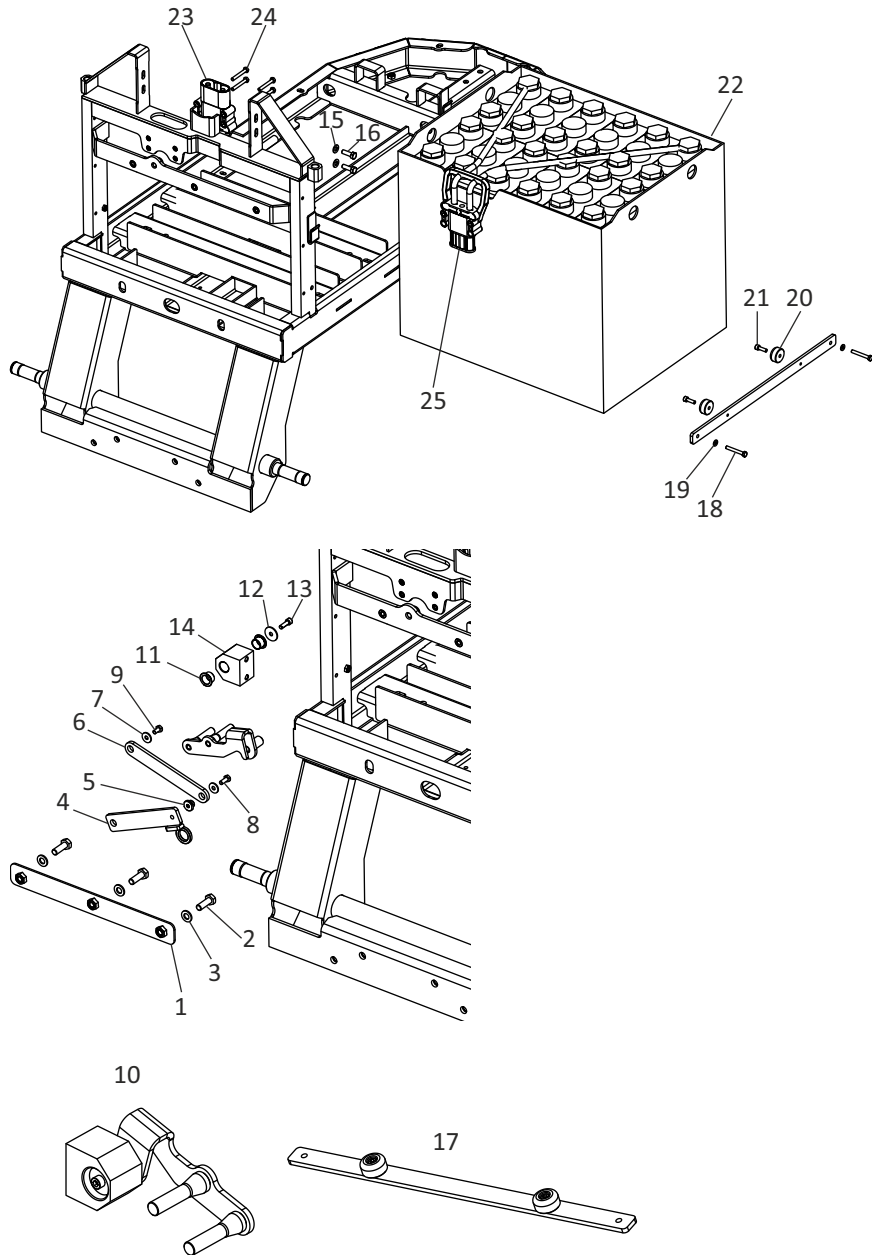

REF. NO	PART NO	DESCRIPTION	QTY
1	55810007-00	COLLECTION TANK TOP HOLDER ASSY	1
2	552020023-00	HEX HEAD SCREW-STEEL8.8-M10X30	3
3	552350018-00	WASHER STEEL-10.5X20X2	3
4	558100079-00	LEVER BOTTOM TANK TILT WELDMENT	1
5	553100257-00	PIN TANK TILT	1
6	553100253-00	LEVER TOP TANK TILT	1
7	552350012-00	WASHER STEEL-6.4X18X1.6	2
8	552020007-00	HEX HEAD SCREW-STEEL8.8-M6X16	1
9	552020006-00	HEX HEAD SCREW-STEEL8.8-M6X12	1
10	558100093-00	ASSY LOCK TANK	1
11	553100295-00	FLANGE BEARING	2
12	552350029-00	WASHER STEEL-6.4X25X1.6	1
13	552230012-00	HEX SOC HEAD CAP SCREW-STEEL-M6X20	1
14	553100294-00	BUSH TANK LOCK	1
15	552350016-00	WASHER STEEL-9X17X1.6	2
16	552020017-00	HEX HEAD SCREW-STEEL8.8-M8X25	2
17	558100077-00	ASSY BATTERY STOPPER 320 Ah	2
18	552020012-00	HEX HEAD SCREW-STEEL8.8-M6X45	4
19	552350011-00	WASHER STEEL-6.4X12.5X1.6	4
20	553100251-00	BUSH BATTERY STOPPER 320 Ah	4
21	552240014-00	HEX SOC HEAD CAP SCREW-SS304-M6X20	4
22 (RB 800, 950)	558100215-00	BATTERY 320 Ah WITH PACKING ASSY	1
22 (RB 800)	558100216-00	BATTERY 240 Ah WITH PACKING ASSY	1
23	558100143-00	ASSY BATTERY PLUG MALE	1
24	552020012-00	HEX HEAD SCREW-STEEL8.8-M6X45	4
25	553100198-00	BATTERY SOCKET (BATTERY)	1

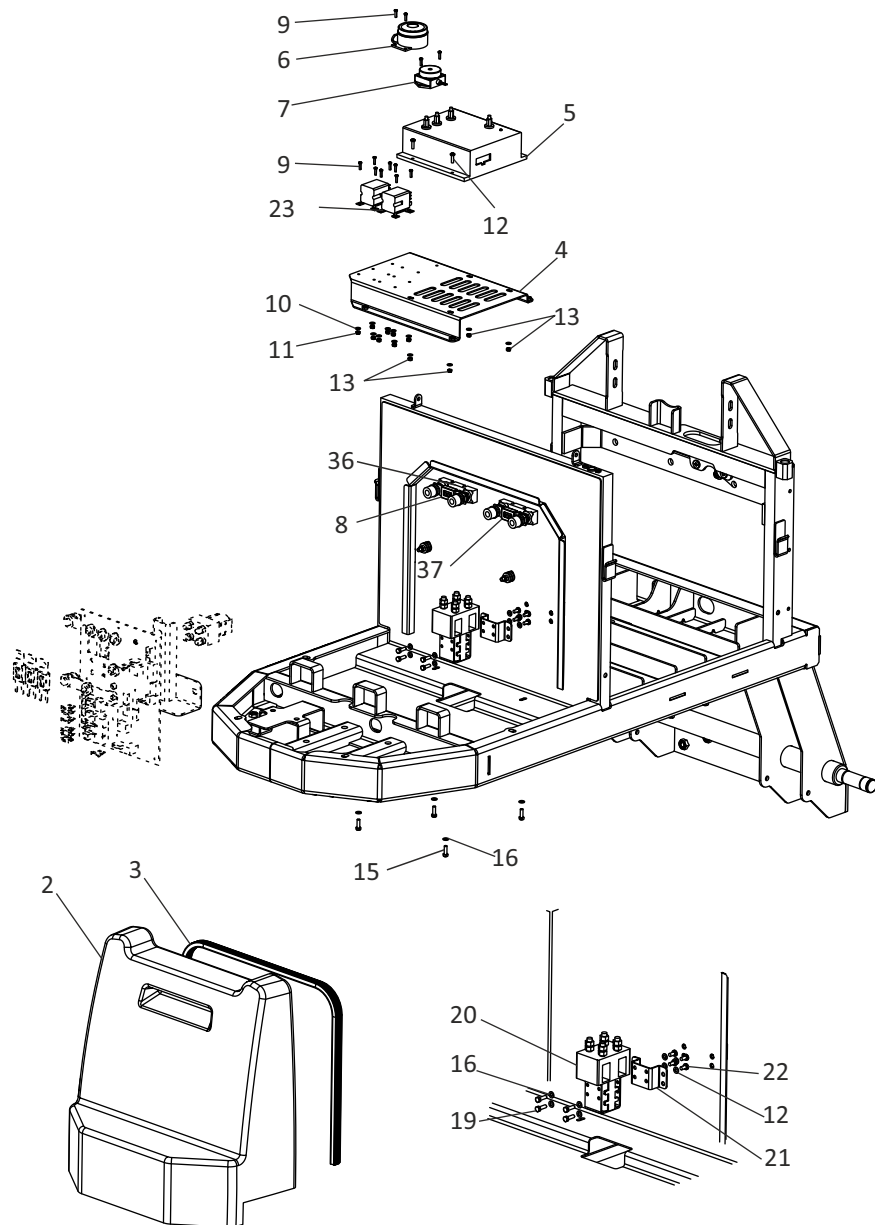

REF. NO	PART NO	DESCRIPTION	QTY
1	558100066-00	ASSY COVER ELECTRICAL GROUP	1
2	553100008-00	COVER ELECTRICAL UNIT	1
3	553100185-00	GASKET ELECTRICAL COVER	1
4	558100248-00	DM CONTROLLER MTG BRACKET WELDMENT	1
5	553100216-00	DM SPEED CONTROLER	1
6	558100139-00	HORN WITH CONNECTOR ASSY	1
7	558100140-00	BUZZER WITH CONNECTOR ASSY	1
8	553100202-00	FUSE BOLT DOWN 125A	1
9	552130002-00	CR PAN HEAD SCREW-STEEL-M3X12	12
10	552350005-00	WASHER STEEL-4.3X9X0.8	16
11	552170003-00	HEX NUT-STEEL GR.8-M3	12
12	552130006-00	CR PAN HEAD SCREW-STEEL-M4X15	4
13	552170005-00	HEX NUT-STEEL GR.8-M4	4
14	558100247-00	DM CONTROLER ASSY	1
15	552020005-00	HEX HEAD SCREW-STEEL8.8-M5X16	4
16	552350008-00	WASHER STEEL-5.3X10X1	12
17	558100085-00	A2 RELAY BOARD ASSY RB800	1
18	558100103-00	ASSY MAIN CONTACTOR RB800	1
19	552020005-00	HEX HEAD SCREW-STEEL8.8-M5X16	4
20	553100191-00	MAIN DC CONTACTOR	1
21	553100293-00	BRACKET MAIN CONTACTOR MOUNT	1
22	552130010-00	CR PAN HEAD SCREW-STEEL-M5X10	4
23	553100649-00	PLA RELAY RB 800	2

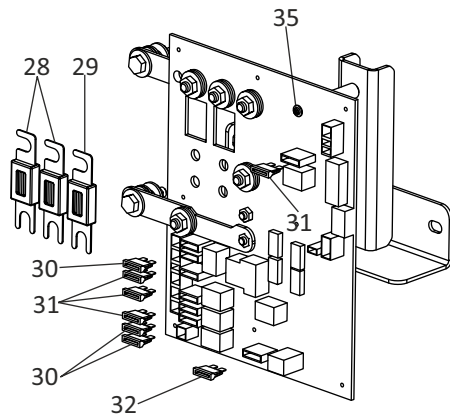
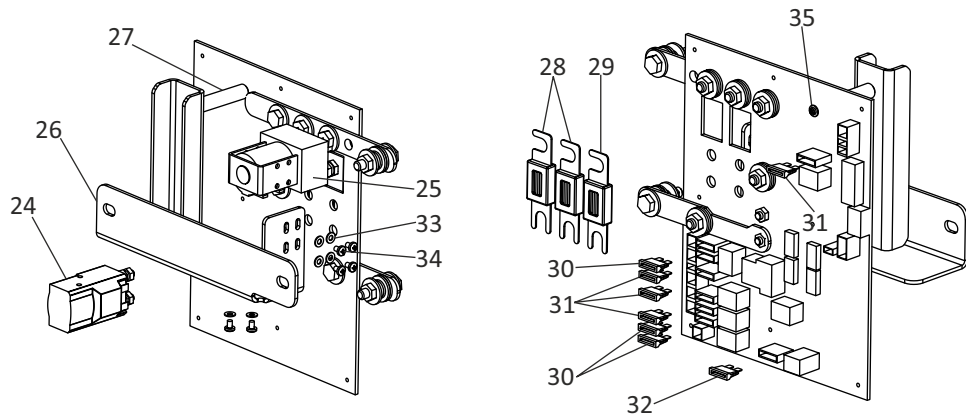

REF. NO	PART NO	DESCRIPTION	QTY
24	553100193-00	VM DC CONTACTOR	1
25	553100192-00	BM DC CONTACTOR	1
26	558100091-00	BRACKET RELAY BOARD MOUNT WELDMENT	1
27	553100291-00	SUPPORT PCB	1
28	553100204-00	FUSE BOLT DOWN 50A	2
29	553100205-00	FUSE BOLT DOWN 35A	1
30	553320472-00	BLADE FUSE 5A	3
31	553100207-00	BLADE FUSE 10A	6
32	553320600-00	BLADE FUSE 2A	2
33	552350005-00	WASHER STEEL-4.3X9X0.8	8
34	552130003-00	CR PAN HEAD SCREW-STEEL-M4X6	6
35	552270002-00	CRPH SELF TAPPING SCREW-2.9X9.5	2
36	553100206-00	FUSE HOLDER-BOLT DOWN FUSE	2
37	553100203-00	FUSE BOLT DOWN - 100A	1
38	552250002-00	LOCK NUT - M5	3
39	552170031-00	COLLAR NUT - M5	1

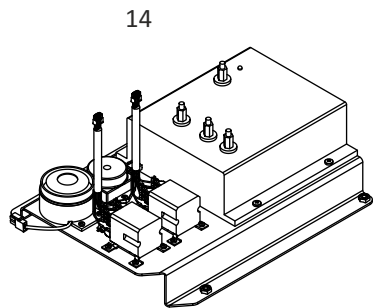
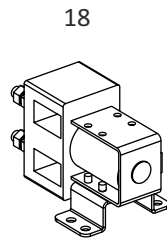
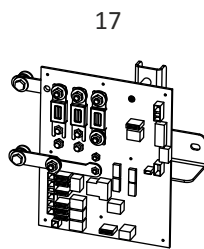
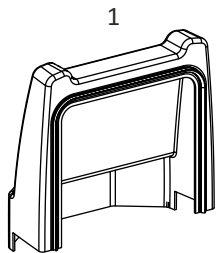

NOTE - Item No. 38 & 39 are not showed in the fig.

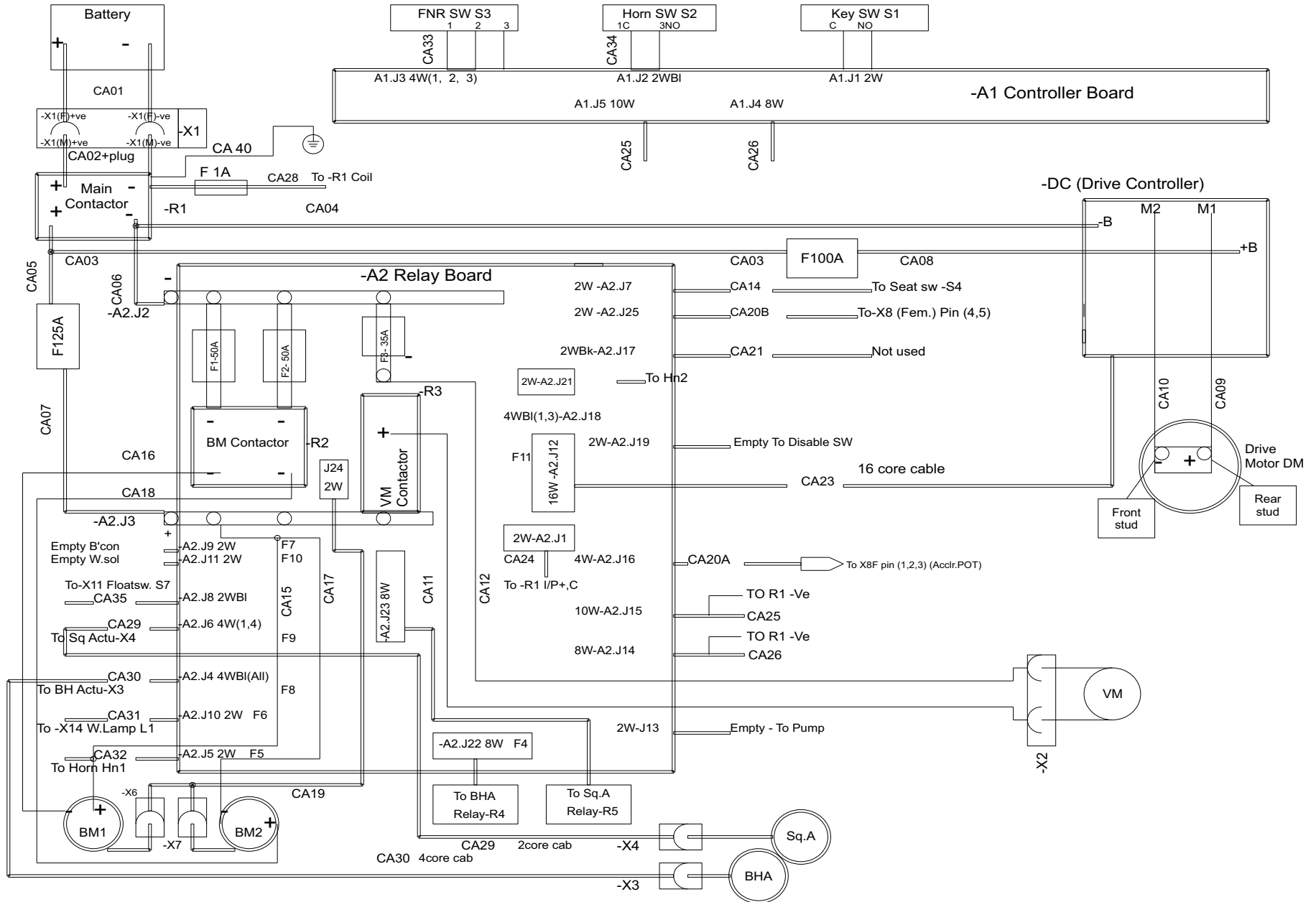

LEGEND	PART NO	DESCRIPTION	QTY	CABLE. NO	PART NO	DESCRIPTION	QTY
BHA	553100214-00	BRUSH HEAD ACTUATOR	1	CA 03	558100114-00	CA 03 (MAIN CONTACTOR TO F 100A)	1
R1	553100191-00	CONTACTOR MAIN	1	CA 04	558100115-00	CA 04 (MAIN CONTACTOR TO DRIVE CONTROLLER)	1
R2	553100192-00	CONTACTOR BRUSH MOTOR	1	CA 05	558100116-00	CA 05 (MAIN CONTACTOR TO F 125A)	1
R3	553100193-00	CONTACTOR VACUUM MOTOR	1	CA 06	558100117-00	CA 06 (MAIN CONTACTOR TO -A2.J2)	1
S1	553320467-00	KEY SWITCH	1	CA 07	558100118-00	CA 07 (F125A TO -A2.J3)	1
S2	553100172-00	HORN SWITCH	1	CA 08	558100119-00	CA 08 (F100A TO DRIVE CONTROLLER)	1
S3	553100171-00	SWITCH FWD/REV	1	CA 09,10	558100120-00	CA 09,10 (DRIVE MOTOR TO DRIVE CONTROLLER)	1
S4	--	SEAT SWITCH	1	CA 11, 12	558100121-00	CA 11,12 (VM CONTACTOR TO -X2)	1
S5	553100126-00	LIMIT SWITCH ACCELERATOR	1	CA 15, 16	558100123-00	CA 15,16 (BM CONTACTOR TO BM1)	1
S6	553100127-00	POTENTIOMETER ACCELERATOR	1	CA 17, 18	558100124-00	CA 17,18 (BM CONTACTOR TO BM2)	1
S7	553320457-00	FLOAT SWITCH	1	CA 19	558100125-00	CA 19 (J24 2W TO -X6 & -X7)	1
BM1	553350779-00	PMDC GEARED MOTOR	1	CA 20	558100126-00	CA 20 (RELAY BOARD TO -X8)	1
BM2	553350779-00	PMDC GEARED MOTOR	1	CA 24	558100128-00	CA 24 (A2.J1 TO -R1)	1
Hn1	553100217-00	HORN	1	CA 28	558100129-00	CA 28 (R1-ve RO R1 COIL)	1
Hn2	553100218-00	BUZZER	1	CA 29	558100130-00	CA 29 (A2.J6 TO X4)	1
F125A	553100202-00	FUSE BOLT DOWN 125A	1	CA 30	558100131-00	CA 30 (A2.J4 TO X14)	1
F100A	553100203-00	FUSE BOLT DOWN 100A	1	CA 31	558100132-00	CA 31 (A2.J10 TO X14)	1
DC	553100216-00	DM SPEED CONTROLER	1	CA 35	558100133-00	CA 35 (A2.J8 TO X11)	1
L1	553100269-00	LAMP HEAD LIGHT	1	CA 33	558100151-00	CA 33 (-A1.J3 TO -S3)	1
DM	553100274-00	DRIVE MOTOR RB 800	1	CA 34	558100152-00	CA 34 (-A1.J2 TO -S2)	1
Sq.A	553100215-00	SQUEEGEE ACTUATOR	1	CA 23	558100153-00	CA 23 (-A2.J12 TO DRIVE CONTROLLER)	1
VM	553100058-00	VACUUM MOTOR 24DC 3 STAGE	1	CA 25	558100202-00	CA 25 (-A1.J5 TO -A2.J15)	1
F4 – 2A	553320600-00	BLADE FUSE 2 A	1	CA 26	558100203-00	CA 26 (-A1.J4 TO -A2.J14)	1
F5 – 5A	553320472-00	BLADE FUSE 5 A	1	CA 40	558100213-00	CA 40 (-R1 -ve TO CHASSIS)	1
F6 – 5A	553320472-00	BLADE FUSE 5 A	1	CA 42	558100413-00	CA42 (-X21 TO -S3)	1
F7 – 5A	553320472-00	BLADE FUSE 5 A	1	DIODE	558100165-00	RB 800 TVS DIODE ASSY	1
F8 – 10A	553100207-00	BLADE FUSE 10 A	1				
F9 – 10A	553100207-00	BLADE FUSE 10 A	1				
F10 – 10A	553100207-00	BLADE FUSE 10 A	1				
F11 – 10A	553100207-00	BLADE FUSE 10 A	1				

For RB 800

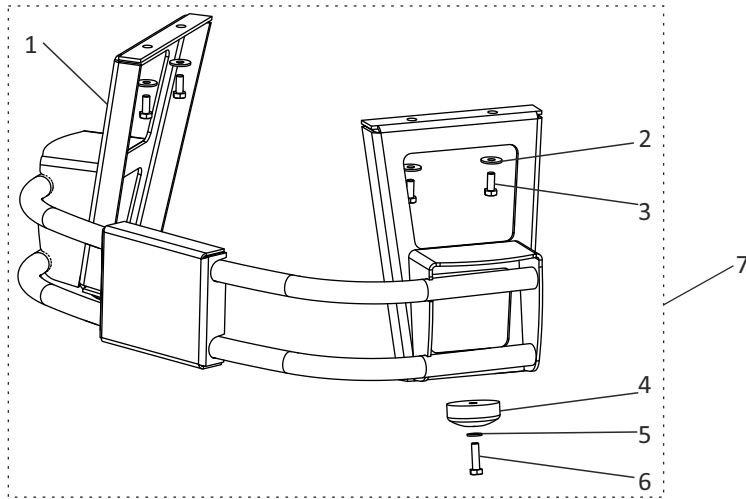

For RB 800

REF. NO	PART NO	DESCRIPTION	QTY
1	558100162-00	ASSY BUMPER FRONT WELDMENT	1
2	552350017-00	WASHER - STEEL - 8.4X24X2	4
3	552040022-00	HEX HEAD SCREW-SS304 - M8X20	4
4	553100117-00	BOOT SIDE SUPPORT	2
5	552040029-00	HEX HEAD SCREW-SS304 - M8X30	2
6	552350016-00	WASHER - STEEL - 9X17X1.6	2
7	558100161-00	FRONT BUMPER ASSY RB 800	1

For RB 950

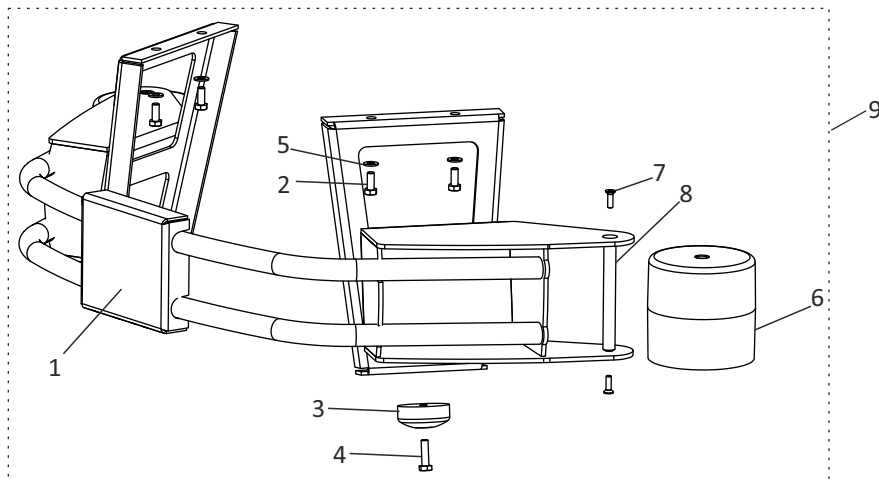

For RB 950

REF. NO	PART NO	DESCRIPTION	QTY
1	558100205-00	BUMPER FRONT WELDMENT	1
2	552040022-00	HEX HEAD SCREW-SS304-M8X20	4
3	553100117-00	BOOT SIDE SUPPORT	2
4	552040029-00	HEX HEAD SCREW-SS304-M8X30	2
5	552350016-00	WASHER - STEEL-9X17X1.6	4
6	553100138-00	DEFLECTOR ROLLER BRUSH HEAD	2
7	552220009-00	HEX SOC CSK HD SCREW SS304-M6X20	4
8	553100405-00	DEF ROLLER MTG PIN	2
9	558100204-00	FRONT BUMPER ASSY RB 950	1

1.a.b.c



2



For RB 800

REF. NO	PART NO	DESCRIPTION	QTY
1.a	558100069-00	BRUSH ASSY 800 - SiC	2
1.b	558100070-00	BRUSH ASSY 800 - PP	2
1.c	558100071-00	BRUSH ASSY 800 - NYLON	2
2	558100159-00	PAD HOLDER ASSY	2
3	558100201-00	SPE CHARGER WITH PLUG	1
4	558100260-00	SQUEEGEE GROUP 1100 - OIL RESISTANT	1
5	558100311-00	HORN KIT	1
6	558100261-00	SQUEEGEE GROUP PARABOLIC 1100	1

3



4

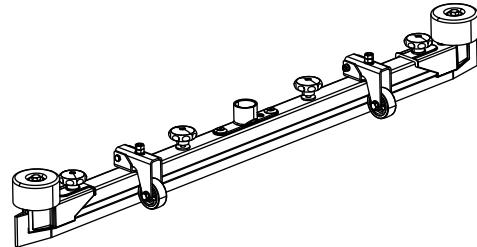

For RB 950

REF. NO	PART NO	DESCRIPTION	QTY
1.a	558100181-00	BRUSH ASSY RB 950 - SiC	2
1.b	558100182-00	BRUSH ASSY RB 950 - PP	2
1.c	558100183-00	BRUSH ASSY RB 950 - NYLON	2
2	558100212-00	PAD & PAD HOLDER	2
3	558100201-00	SPE CHARGER WITH PLUG	1
4	558100400-00	ADD ON WEIGHT BUMPER KIT - RB 950	1
5	558100324-00	SOLENOID VALVE KIT	1
6	558100322-00	CABLE ASSY SOLENOID VALVE	1

5

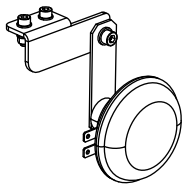

Other optional accessories

REF. NO	PART NO	DESCRIPTION	QTY
1	558100318-00	SEAT BELT KIT	1
2	558100324-00	SOLENOID VALVE KIT	1
3	558100322-00	CABLE ASSY SOLENOID VALVE	1
4	558100331-00	ADD ON WEIGHT BUMPER KIT	1
5	558100316-00	BATTERY 200Ah KIT	1

A series of horizontal dotted lines for taking notes, spanning the width of the page.

BLANK

THIS PAGE IS LEFT INTENTIONALLY BLANK



Roots Multiclean Ltd.

R.K.G. Industrial Estate, Ganapathy,
Coimbatore - 641 006, India

Phone: +91 (422) 4330 330
Email: rmclsales@rootsemail.com
Web: rootsmulticlean.in
Toll Free: 1800 425 1330